



Service Manual



TM25S / TM30S

Hardware Version: 5.02

Document version: 0

Release Date: 2024-07-23

This Manual contains information of the Techman Robot product series (hereinafter referred to as the TM Robot). The information contained herein is the property of Techman Robot Inc. (hereinafter referred to as the Corporation). No part of this publication may be reproduced or copied in any way, shape or form without prior authorization from the Corporation. No information contained herein shall be considered an offer or commitment. It may be subject to change without notice. This Manual will be reviewed periodically. The Corporation will not be liable for any error or omission.

 and  logo is registered trademark of TECHMAN ROBOT INC. in Taiwan and other countries and the company reserves the ownership of this manual and its copy and its copyrights.

 TECHMAN ROBOT INC.



1. Handling components that are sensitive to electrostatic discharge (ESD)	3
2. Safety information.....	3
3. Description of Robot and control box parts	4
4. TM25 Maintenance Notes.....	12
5. Tool list	12
6. Assembly and Disassembly Guide for Robot.....	17
7. Control BoxDisassembly /Assembly Control Box	40
8. Indication Light.....	52
9. Other Software for support functions.....	58
10. Calibration guide	68
11. Trouble shooting	84

1. Handling components that are sensitive to electrostatic discharge (ESD)



To prevent ESD-sensitive components (e.g., printed circuit boards) from being damaged, please handle the components in the following steps:

- Wear an anti-static wrist strap before replacing ESD sensitive components and make sure the bracket is always connected to ground when replacing components.
- Hold the protective cover for the component's edge connect and avoid touching any exposed part.
- Drop the replaced component into an antistatic bag

2. Safety information



DNAGER :

Identifies an imminently hazardous situation that, if not avoided, is likely to result in serious injury, and might result in death or severe property damage.



WARNING:

Identifies a potentially hazardous situation that, if not avoided, will result in minor or moderate injury, and might result in serious injury, death, or significant property damage.



CAUTION:

Identifies a potentially hazardous situation that, if not avoided, may result in minor injury, moderate injury, or property damage.

3. Description of Robot and control box parts

3.1 TM25S/TM30S : Robot Spare parts

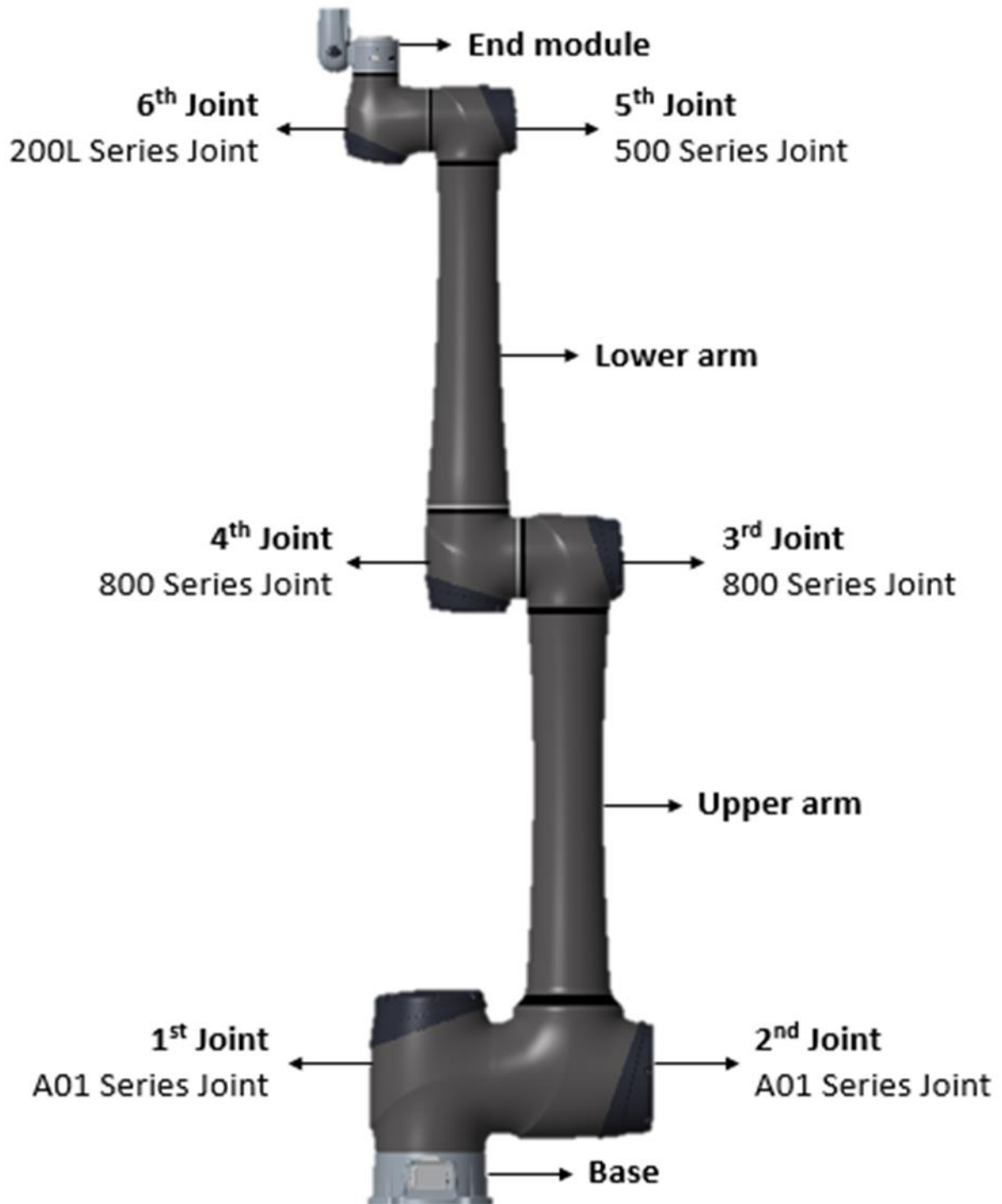

3.2 TM25SX/TM30SX : Robot Spare parts

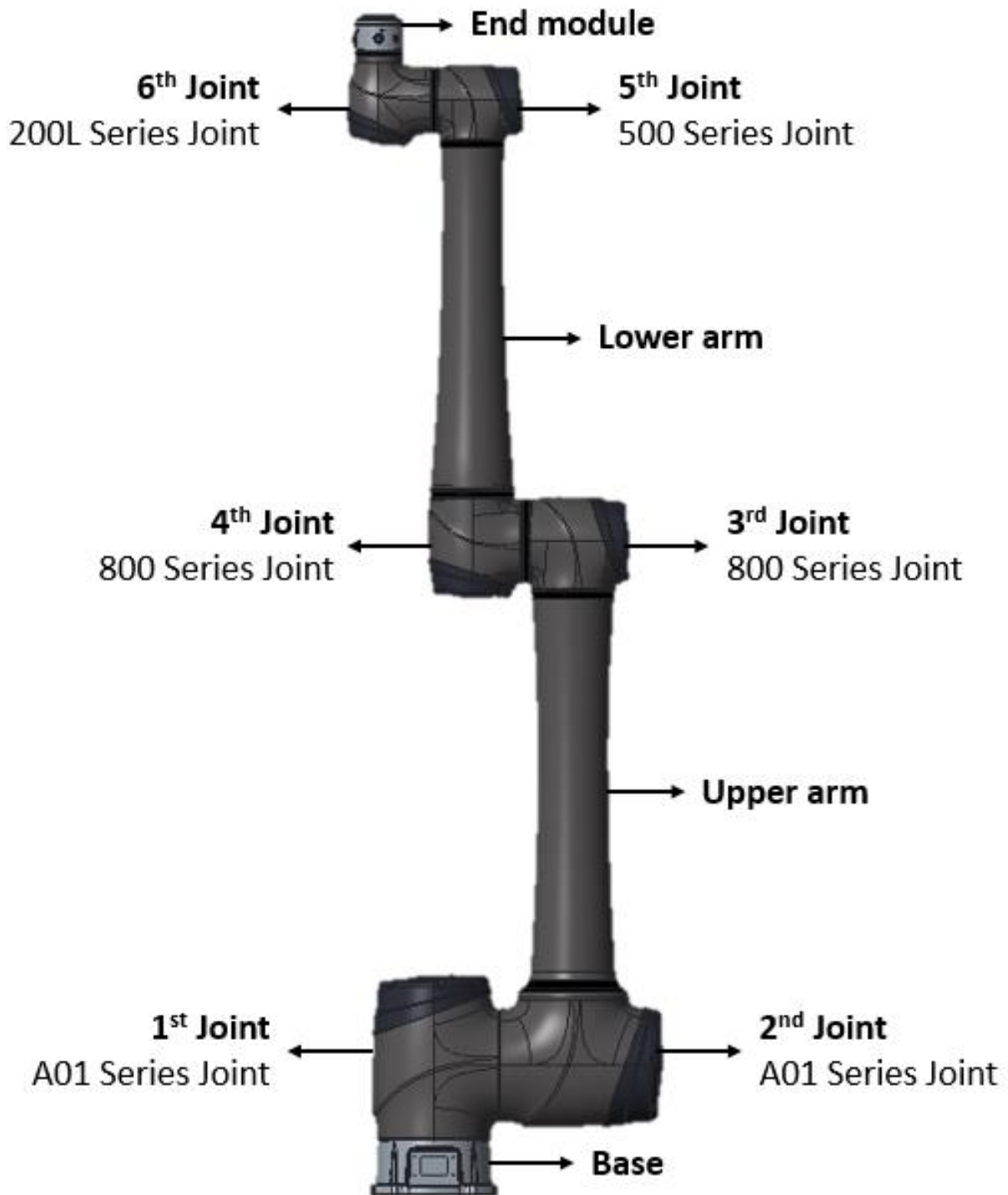

3.3 A01 Series Joint

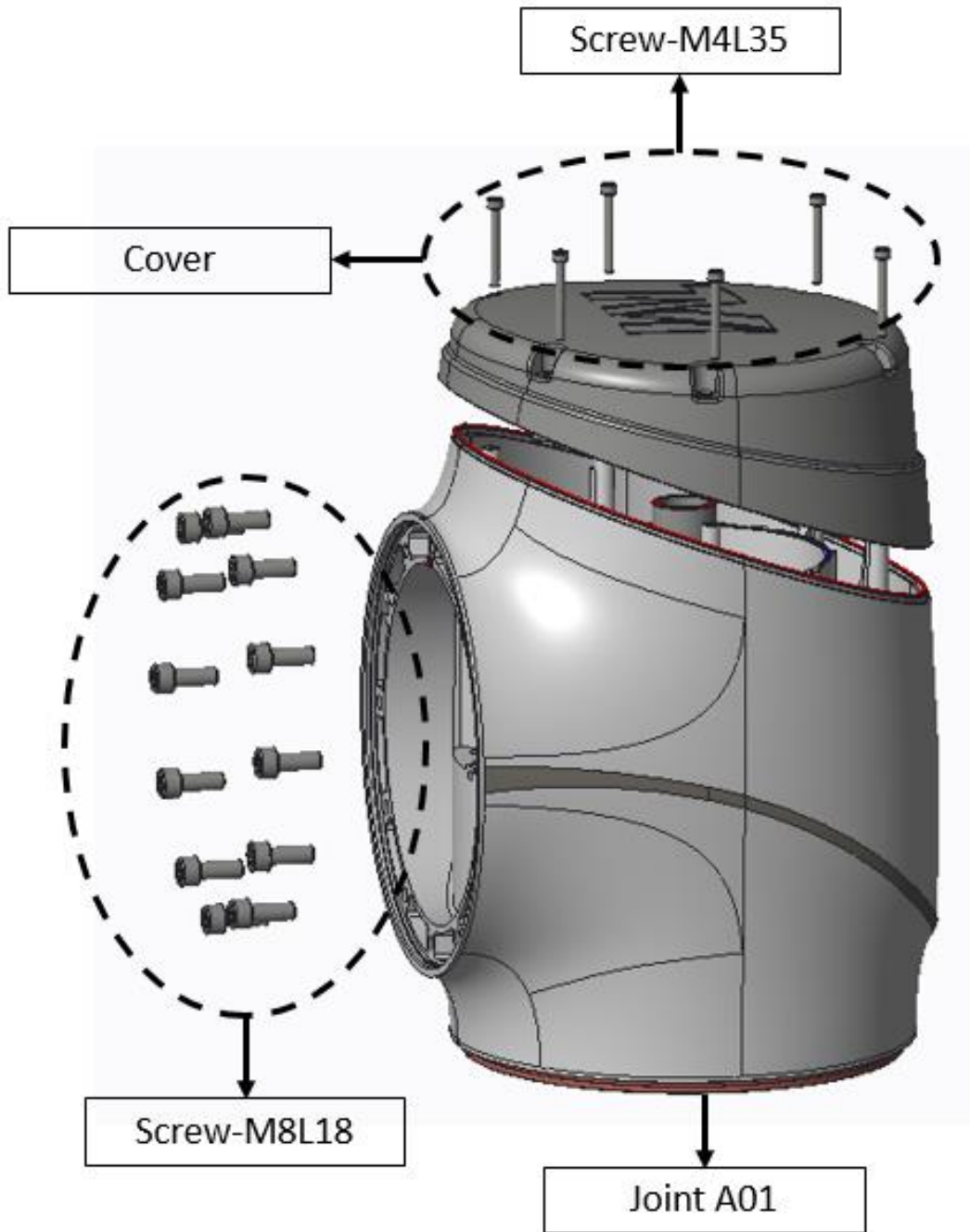

3.4 800 Series Joint

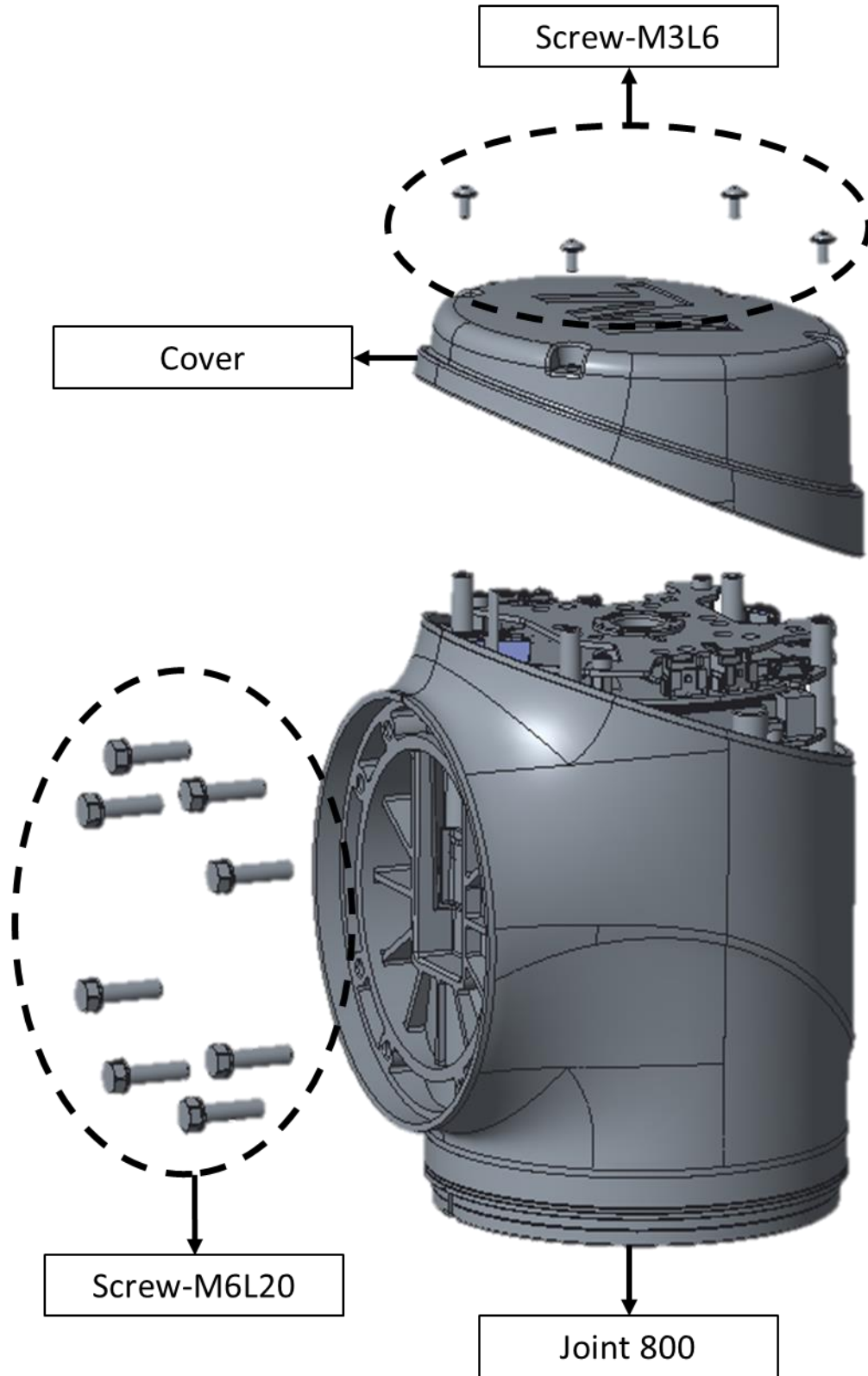

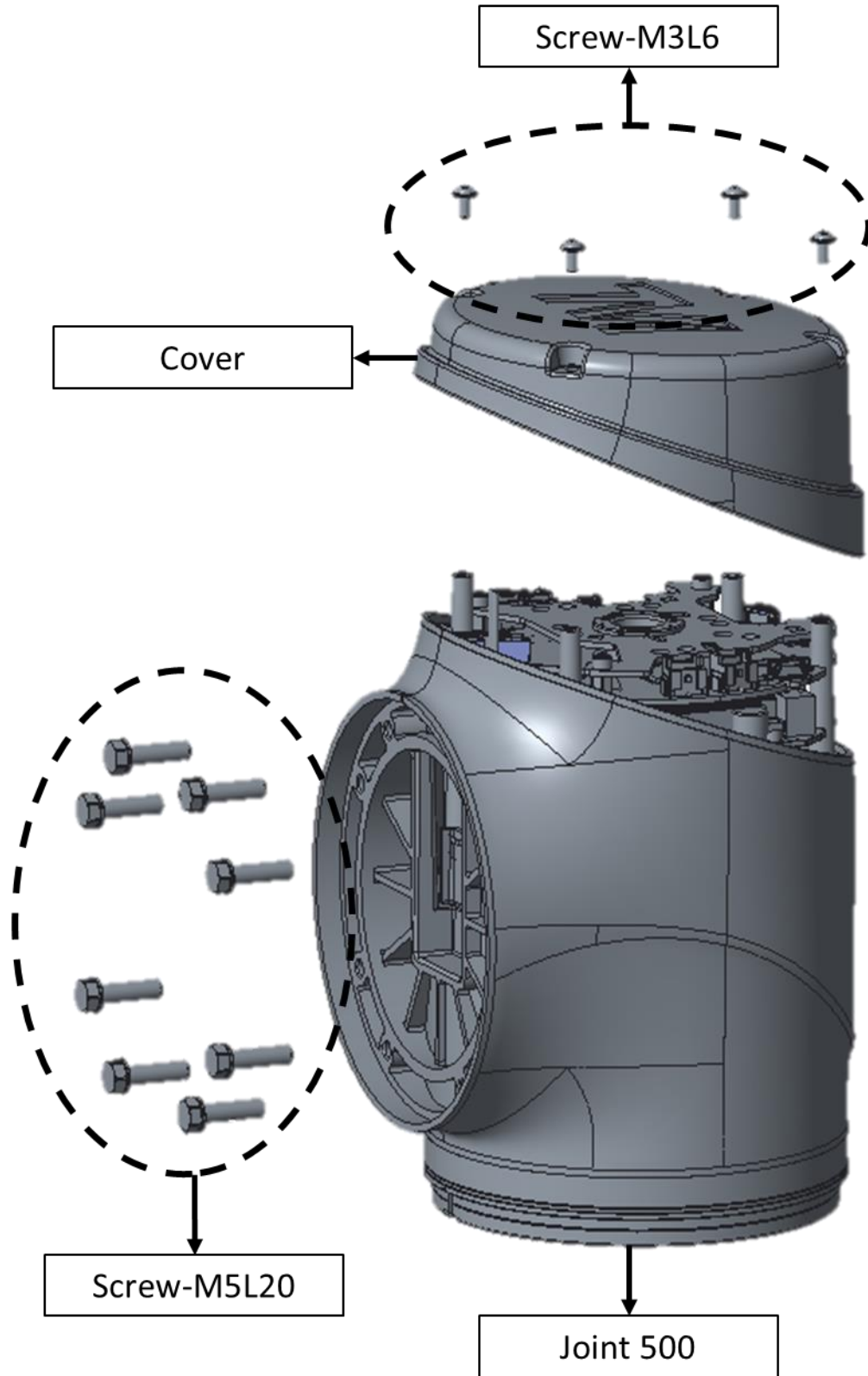

3.6 200L Series Joint

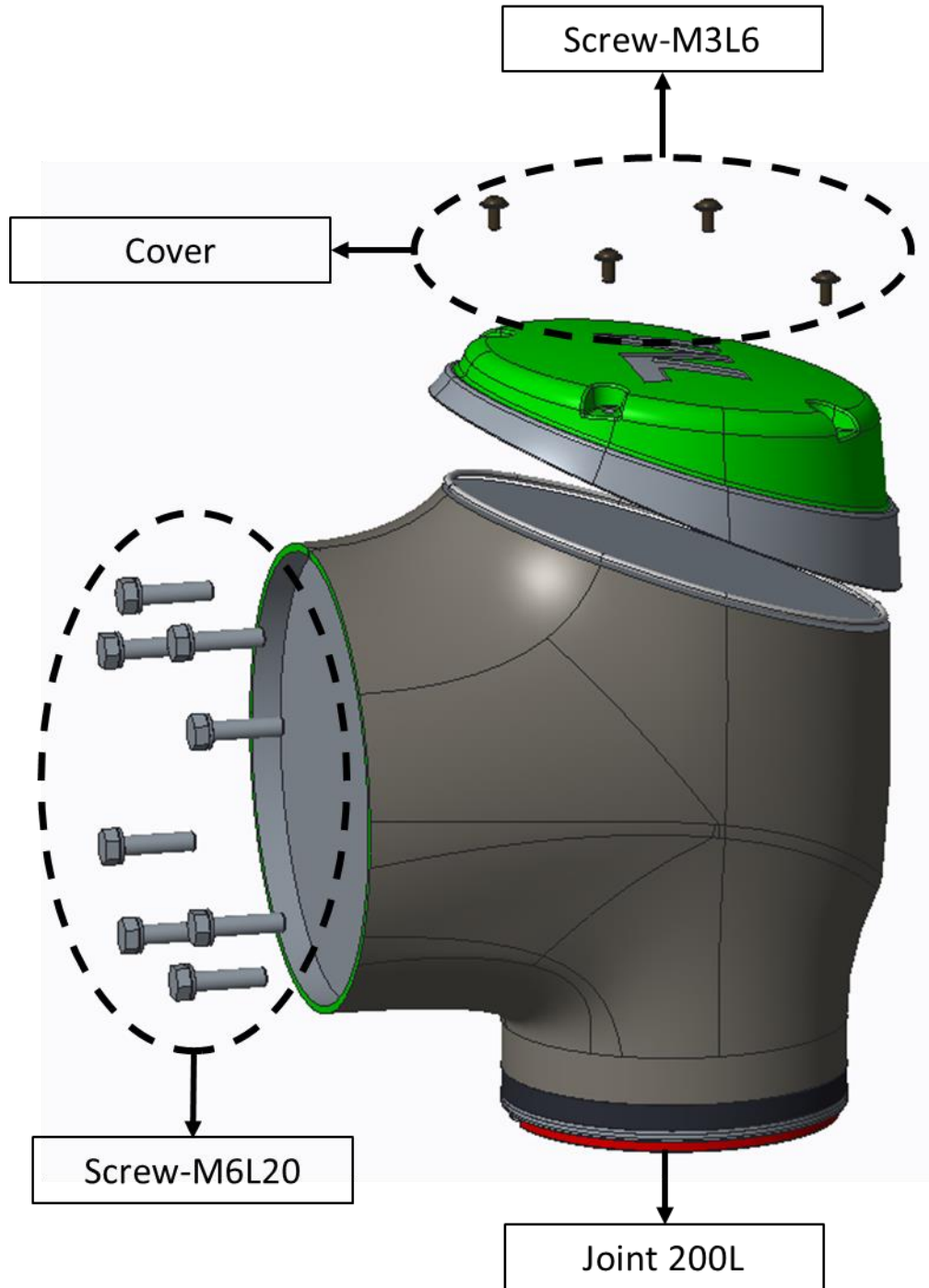

3.7 End module

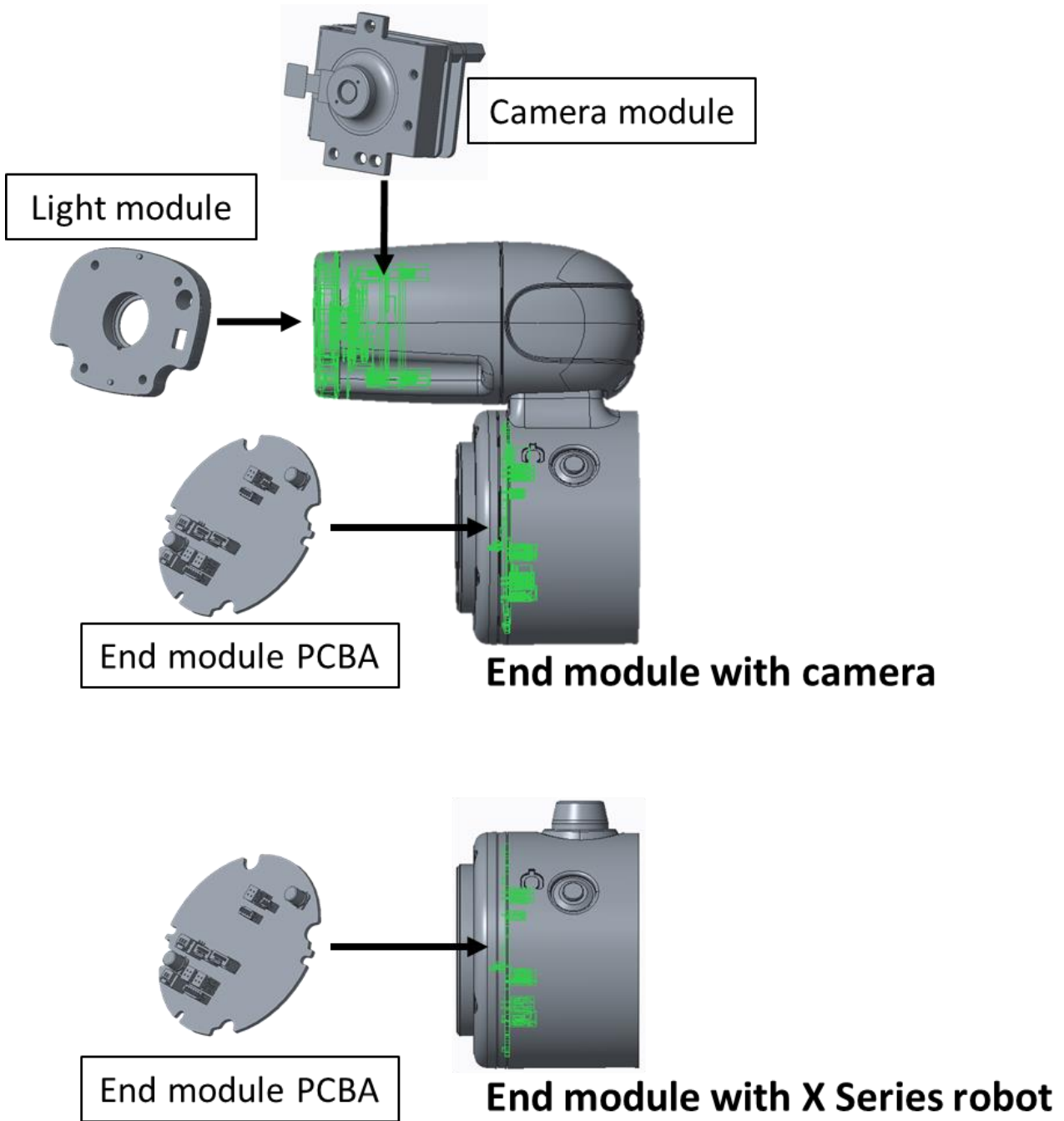

3.8 Control Box

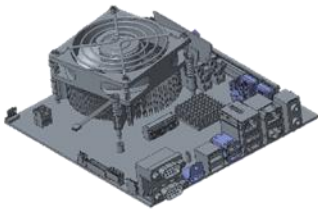
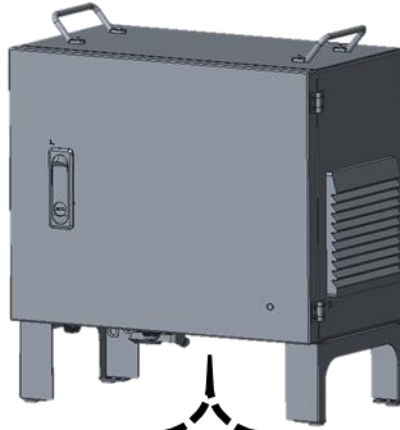

IPC

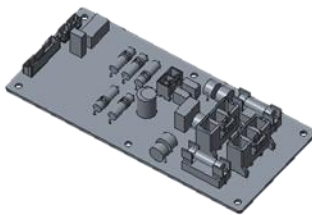

Relay board

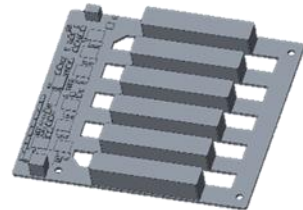

Power eater

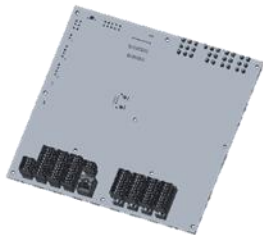

Patriot power board



48V PSU *2

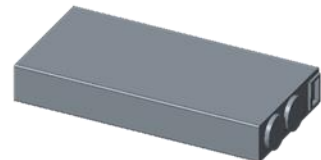

24V PSU

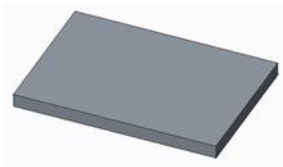

SSD (with RTX)



Stick

4. TM25S/TM30S Maintenance Notes

4.1 When performing lifting, dismantling, maintenance, and calibration operations, it is recommended to place the robot in a spacious area. The following are the suggested space requirements:

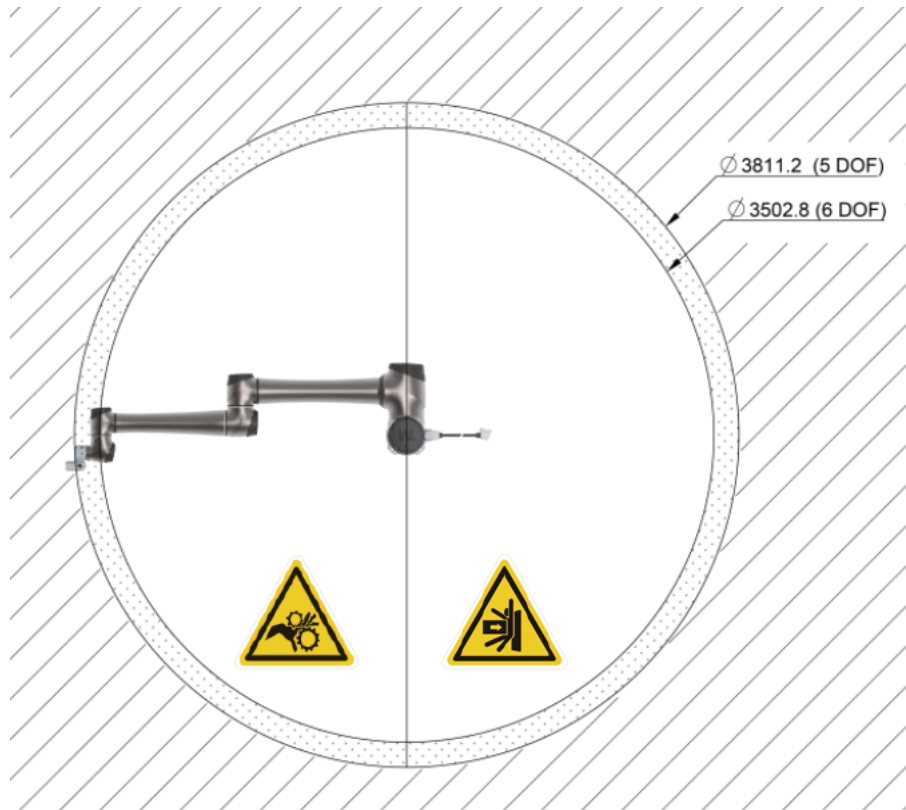



4.2 For lifting or transporting robots, please refer to the "Moving the package robot" section in the hardware manual.

4.3 When it is necessary to rotate joint in an unpowered state, please refer to the "Joint Movement Without Drive Power" section in the hardware manual.

5. Tool list





5.1 Recommended Tool List for TM25S Maintenance



[Contact Techman to purchase tools.](#)

Name	Physical Reference	Specification	Model	Remarks
Ratchet Torque Wrench		20~100 N.m (200~1000 kgf.cm)	KANON N100QLK	Used for installation and removal A01 Series Joint
Linkage		at least 400mm Techman Robot	Techman Robot	linkage is used in conjunction with a ratchet torque wrench and a T45 Torx screwdriver to disassemble the A01 Series Joint.

Hardware Version : 5.02 Document Version : 0

TECHMAN ROBOT INC. 5F., No. 58-2, Huaya 2nd Rd., Guishan Dist., Taoyuan City, 333411, Taiwan

Name	Physical Reference	Specification	Model	Remarks
Magnetic torx Bit		T45		Used for installation and removal A01 Series Joint
Cut-Resistant Gloves		Features anti-slip and cut-resistant protection		Used to protect personnel's hands and provide anti-slip functionality
Soft Shell Cap		NA		Used to protect the head of maintenance personnel
Steel Toe Safety Shoes		NA		Used to protect the feet of maintenance personnel
Crane		500-1000kg length 2.5m height 3m	PORTA GANTRY 500kg	Used for moving the robot
lifting jig		Techman Robot	Techman Robot	Used to secure onto the A01 Series Joint, facilitating the crane lifting or handling of personnel after disassembling the joint
TM25 maintenance platform		Recommended Specifications: Length: 90cm Width: 90cm Weight: 100kg		Please refer to the hardware manual for the robot base hole positions and dimensions. When assembling, make sure to secure the bottom swivel feet
Shackle		weight 2T width 20mm		Install on the lifting jig so that the rope can lift the joint.
Eye bolt		M8 x L15mm		Install on the lifting jig so that the rope can lift the joint.















Name	Physical Reference	Specification	Model	Remarks
48V PSU		DC48V & 4A	Refer to Hardware manual	Used for operating a robot without drive power. Refer to hardware manual for settle the power souce.
Torque screw driver		6 – 26 kgf·cm	TOHNICHI 26RTD	Used for assembling A01 Series joint cover



5.2 Tool List Commonly Used for Other Arm Models (TM5S, TM7S, TM12S, TM14S)

Name	Physical Reference	Specification	Model	Remarks
Open end wrench		5.5 mm		Used for IO module
Open end wrench		8 mm		Used for 500 Series Joint
Open end wrench		10mm		Used for 800 Series Joint
Hex socket screwdriver		5.5 mm		Used for IO module
Hex socket screwdriver		8 mm		Used for 500 Series Joint
Hex socket screwdriver		10mm		Used for 800 Series Joint
Torque wrench		5.5 mm 20 kgf·cm	TOHNICHI 50CL-MH	Used for IO module
Torque wrench		8 mm 92 kgf·cm	TOHNICHI 150CL-MH	Used for 500 Series Joint
Torque wrench		10mm 250kgf·cm	TOHNICHI 225CL-MH	Used for 800 Series Joint
Wrench head		SH8D × 5.5 5.5 mm	TOHNICHI SH8D*5.5	Used for IO module
Wrench head		SH8D × 8 8 mm	TOHNICHI SH8D*8	Used for 500 Series Joint
Wrench head		SH10Dx10 10mm	TOHNICHI SH10D*10	Used for 800 Series Joint
Torque screw driver		6 – 10 kgf·cm	TOHNICHI 10RTD	Used for Cover, Control box
Torx bit		T10		Used for Joint cover

Hardware Version : 5.02 Document Version : 0

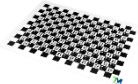
TECHMAN ROBOT INC. 5F., No. 58-2, Huaya 2nd Rd., Guishan Dist., Taoyuan City, 333411, Taiwan

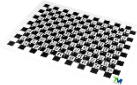
Name	Physical Reference	Specification	Model	Remarks
Hex bit		Bit 2.5mm x length 100mm		Used for outer cover of camera module
Hex wrenches		M1.5–M10		Used for Base and Control box
Extension bit Holder		1/4 inch At least 150mm magnet type is recommended		Used for internal box's fixed screws..
Hex socket bit		M10		Used for internal box's fixed screws, magnet type is recommended.
Phillips screw driver				Used for control box components
Tweezer				Used for removing cables
Adjustable spanner		8 inch		Used for robot cable
Diagonal cutting plier				Used for cutting cable ties
Long nose plier				Used for removing cables
Cable tie		120 × 2.5 mm ²		Used for securing wires
Cable tie		150 × 3.6 mm ²		Used for securing wires
Multimeter				Used for checking voltage and circuit
Precision screwdriver set		T06151		Used for screws
Electrical tape		Width: 18mm		Used for wrapping around camera cable connectors
USB flash drive				Used for Windows recovery
Dongle key			Techman Robot	Must contain authorization key of maintenance
2-cm Plate calibration		40 cm × 30 cm	Techman Robot	Used for camera calibration

Name	Physical Reference	Specification	Model	Remarks
1-cm Plate calibration		20 cm × 15 cm	Techman Robot	Used for camera calibration
TM Landmark			Techman Robot	Used for Kinematic calibration and Hand-eye calibration

6. Assembly and Disassembly Guide for Robot

6.1 Quick maintenance guide

6.1.1 To ensure operational safety, disassembly of Joint 1 and Joint 2 requires the collaborative effort of at least three people. Disassembly of other components requires a minimum of two people working together.

6.1.1 Before disassembly, ensure that the robot is completely powered off completely and that both the external power cord and robot cable have been disconnected.

6.1.2 Before disassembly, remove the robot from the platform and place it horizontally on a non-hard surface (e.g., blanket or sponge pad).

6.1.3 Before disassembly, take photos to record the status and wiring configuration. These photos will serve as reference points during the reassembly process.

6.1.4 Follow the right-hand rule when disassembling and installing screws.

6.2 Disassembly and assembly of Joint cover and Joint rubber

6.2.1 Joint cover disassembly: To disassemble the joint cover, use a hex cap screwdriver to loosen the four hexagonal socket head cap screws (Fig. A). Then, gently remove the cover by hand, being careful to keep the O-ring in the groove.

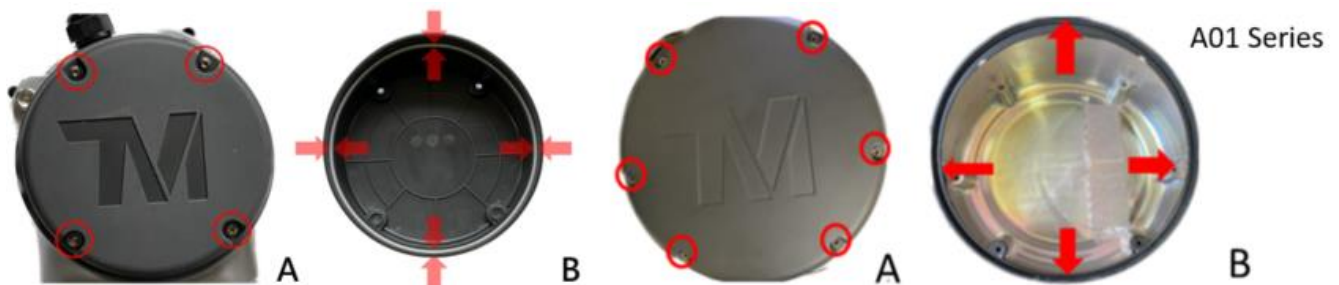

6.2.2 Joint cover assembly: To assembly the joint cover, ensure that the O-ring is in the groove (Fig. B) and tighten the four socket head cap screws using a torque screwdriver and a socket head torque screwdriver.



CAUTION:

Use the correct torque to tighten the screws according to the table below. Insufficient torque may result in inadequate sealing of the joint cover. Excessive torque during screw tightening may cause damage to the joint cover.

Torque specifications for Joint screws

Joint Type	Screw Type	Torque Value (Kgf.cm)	Torque Value(Nm)	Total Screws
200L series	M3L6 TORX SOCKETHEAD CAP	6	0.6	4
500 series	M3L6 TORX SOCKETHEAD CAP	6	0.6	4
800 series	M3L6 TORX SOCKETHEAD CAP	6	0.6	4
A01 Series	M4L35 TORX SOCKETHEAD CAP	25	2.5	6

6.2.3 Remove Joint Rubber: Remove the Rubber with tweezers and open the white anti-dust cover to reveal the 200 Series / 500 Series / 800 Series Joint Screws.

6.2.4 Reverse the previous steps to install the dust cover and Rubber.

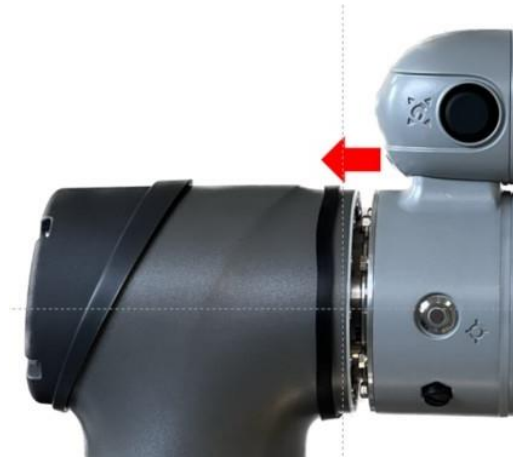

6.2.5 Removal of A01 Series Joint rubber: Use a flathead screwdriver to pry open the Rubber upward, revealing the screws for the A01 Series Joint. Reverse the above steps to reinstall the Rubber.



6.3 Disassembly and assembly Joint cable

6.3.1 A01 Series Joint

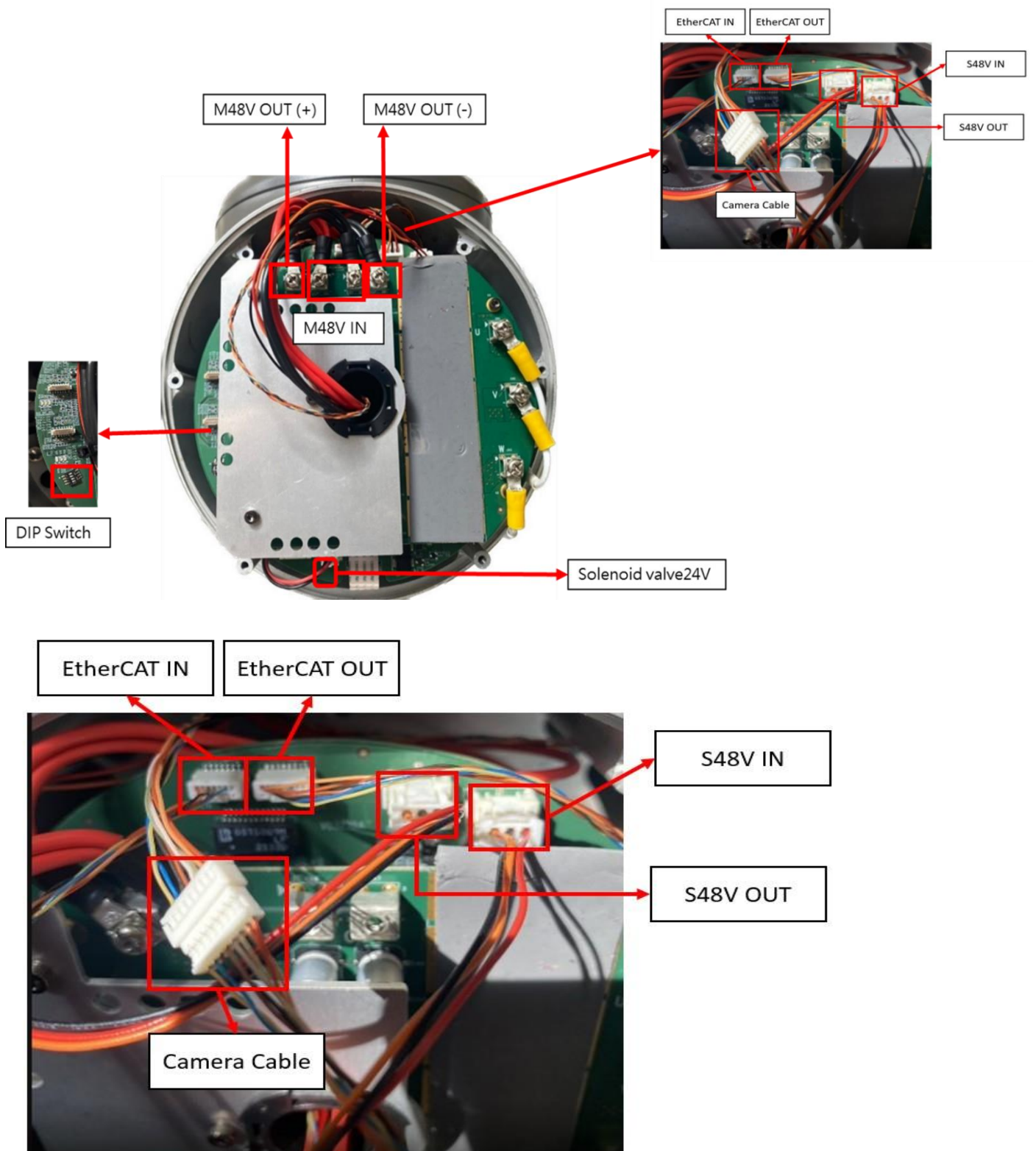

6.3.2 800 Series Joint

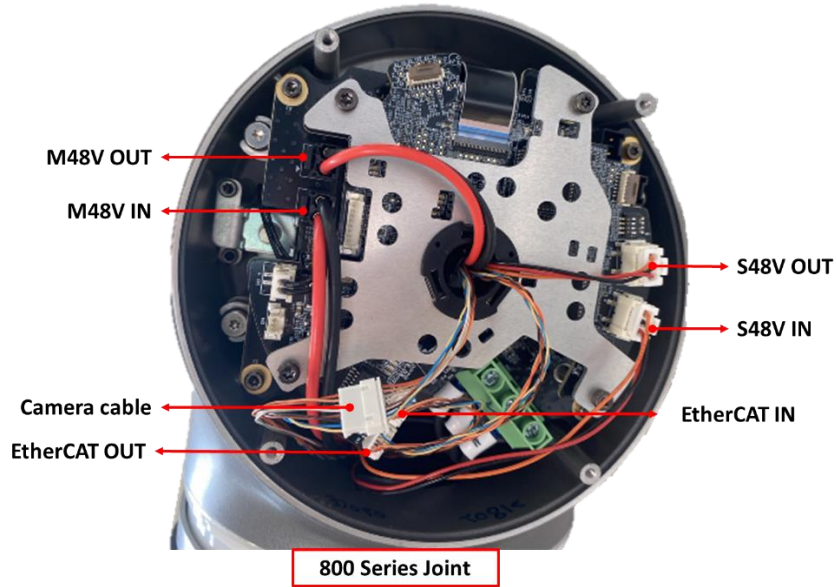

6.3.3 500 Series Joint

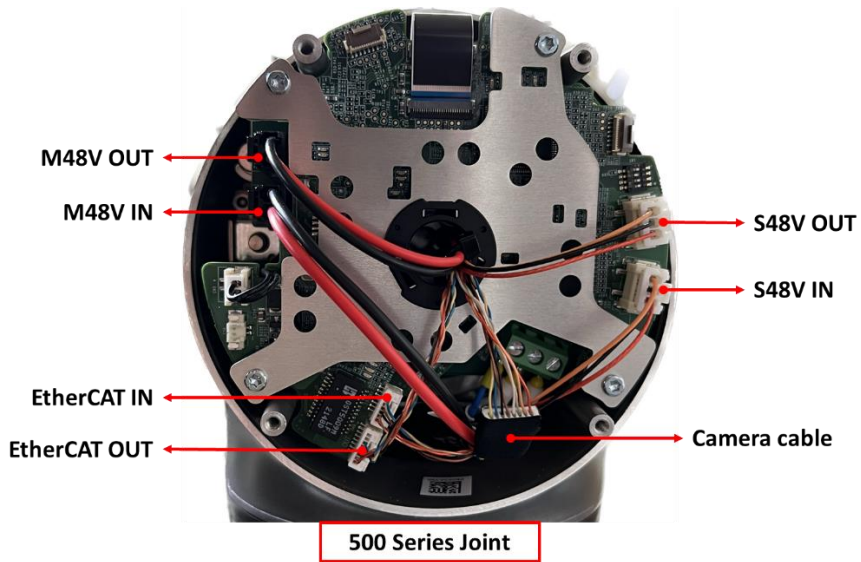

6.3.4 200L Series Joint

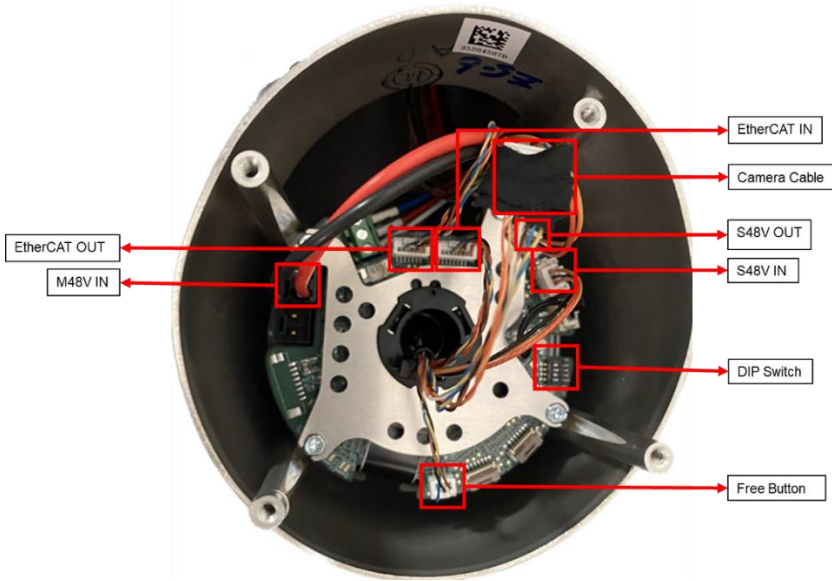

6.4 Camera Cable location

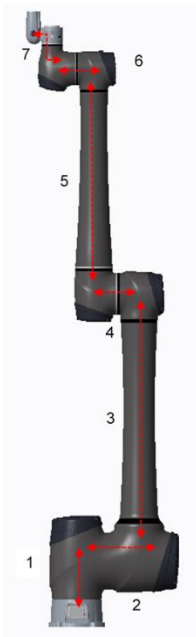

6.5 Disassembly and Assembly Joint screw



CAUTION: Before remove Joint screws, ensure the Joint cables and connectors are disconnected; failure to disconnect the cable may result in damage to the Joint cable or components due to pulling or interference when removing the Joint.

6.5.1 Before remove Joint screws, remove Joint Cover and Joint Rubber.

6.5.2 Using open end wrench to loosen the screw for Joint connecting screws

Front View



A01 Series



Side View

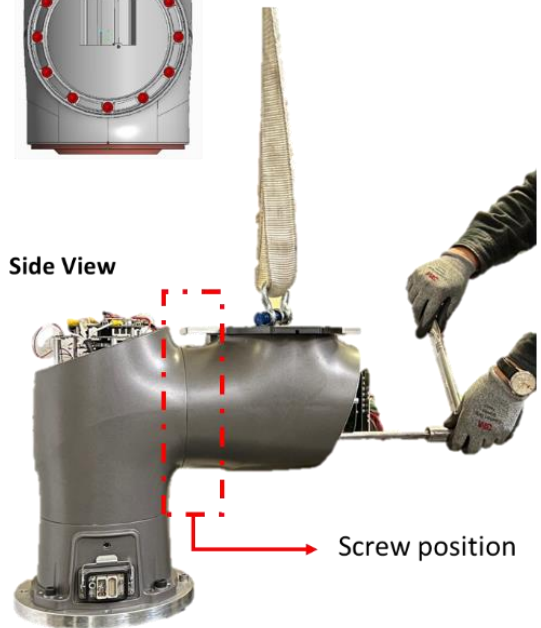



DANGER: Repeated use of disassembled screws is prohibited, as the screw adhesive on the screws will become ineffective, and the repeated use will increase unforeseen risks.



DANGER: Tighten the joint screws according to the specified torque value provided below.

Torque specifications for Joint screws

Joint Type	Screw Type	Torque Value (Kgf.cm)	Torque Value(Nm)	Total Screws
200L series	M3L14 HEX HEAD CAP	20	2.0	8
500 series	M5L20 HEX HEAD CAP	92	9.0	8
800 series	M6L20 HEX HEAD CAP	150	15	10
A01 series	M8L18 HEX HEAD CAP	180/370	18/37	10

6.5.3 When assembling the joint, to ensure the correct installation orientation, it is necessary to interlock the key and slot between the joints (refer to Figure 1 & Figure 2) (refer to Figure 3). Operators can visually align the holes or insert a $\varnothing 1.9\text{mm}$ pin into the hole to verify proper installation (refer to Figure 4). If the hole of two joints are not in the same direction, or if misalignment prevents the insertion of the locating pin, do not proceed with further assembly.

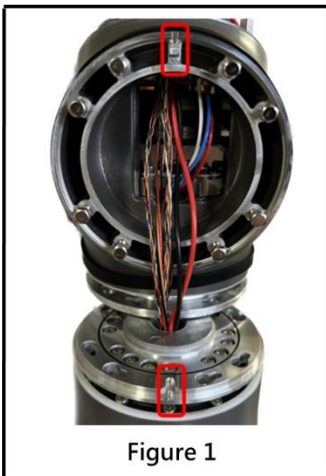

Figure 1

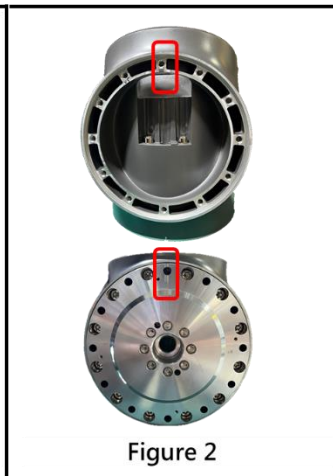

Figure 2

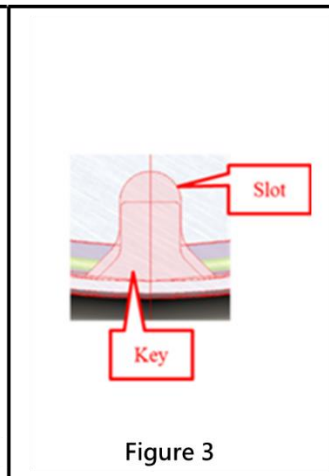

Figure 3



Figure 4

6.6 Disassembly and Assembly of Base and Robot Cable

6.6.1 Before removing the Base cover, loosen the corresponding screws and disconnect the wiring between the Robot cable and Joint 1.

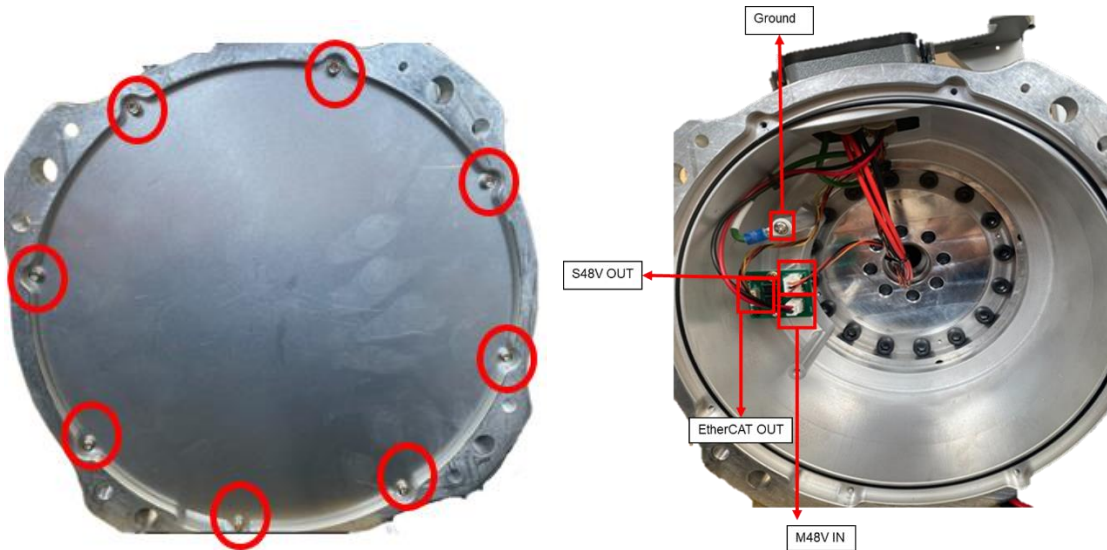

6.6.2 Remove the connector screws.

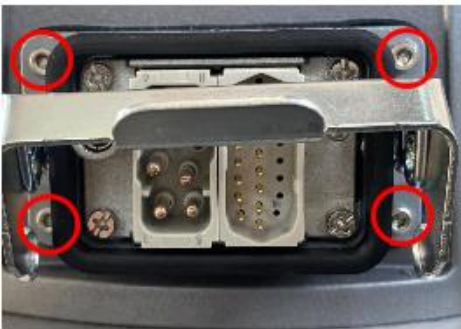

6.6.3 When assembling the Base and Robot cable, please follow the reverse steps of the previous procedure.

6.7 Disassembly and assembly A01 Series Joint – Joint 1

6.7.1 Before disassembling Joint 1, disassemble Joint 2 to the End Module.

6.7.2 Rotate Joint 1 to the home position and ensure that all joint screws are visible.

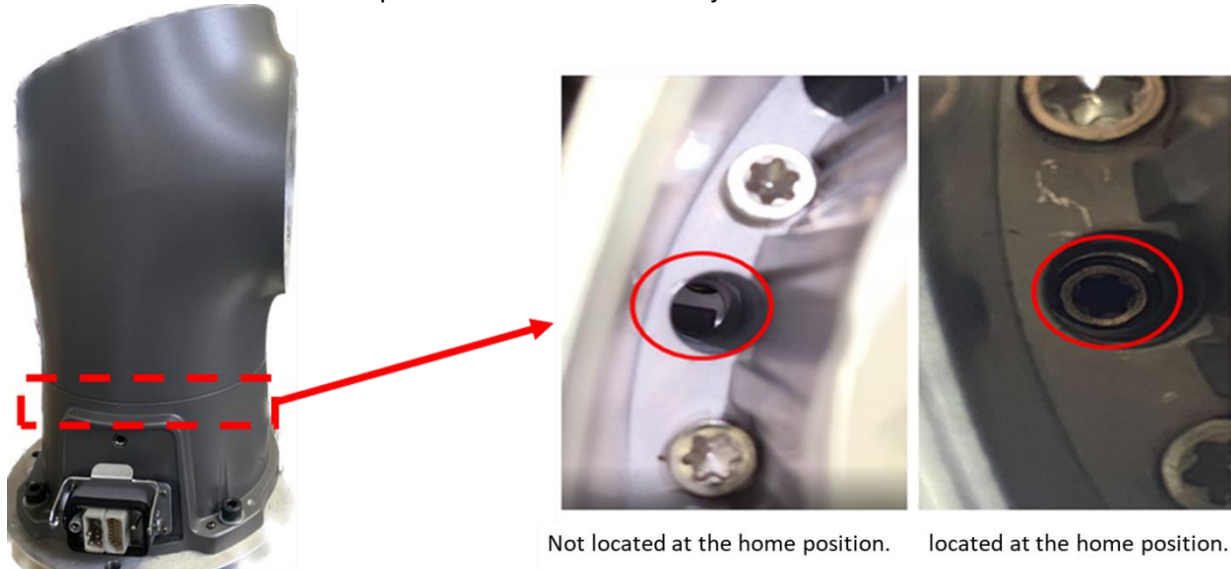

6.7.3 Remove the Joint Cover of Joint 1.

6.7.4 Remove the Joint Cable of Joint 1.

Hardware Version : 5.02 Document Version : 0

TECHMAN ROBOT INC. 5F., No. 58-2, Huaya 2nd Rd., Guishan Dist., Taoyuan City, 333411, Taiwan

6.7.5 Install the lifting jig, secure the lifting rope to the auxiliary tool, and adjust the lifting rope slightly tight to prevent the Joint from tilting in other directions after the Joint connection screws are removed.



6.7.6 Remove the connection screws between Joint 1 and the Base, and take off Joint 1.

6.7.7 When assembling Joint 1, align the Key and Slot of the A01 Series Joint in the figure below and follow the previous steps in reverse. °



Caution: When assembling the A01 series joints, make sure that the A01 series joint key is securely attached to the slot to prevent abnormal operation of the arm controller or unexpected errors.

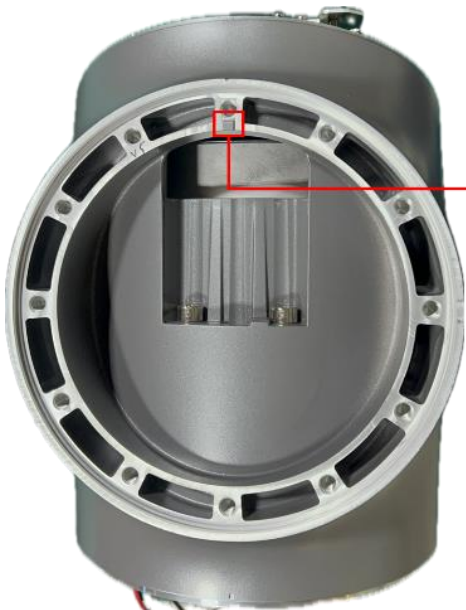

A01 Series Joint Screw Side

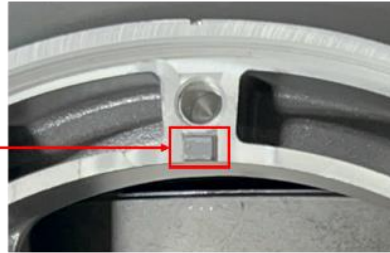

A01 Series Key Slot

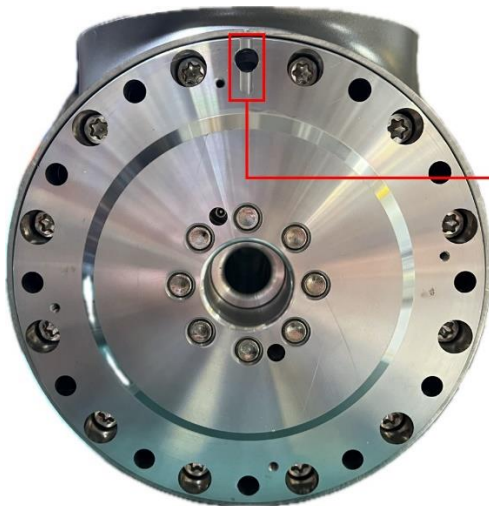

A01 Series Joint Flange Side

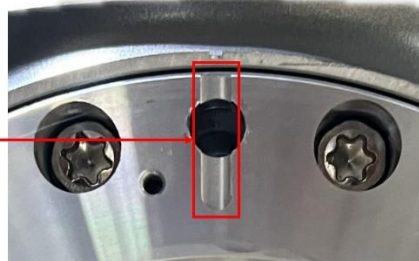

A01 Series Flange Slot

6.8 Disassembly and assembly A01 Series Joint – Joint 2

6.8.1 Before disassembling Joint 2, disassemble Upper arm to the End Module.

6.8.2 Rotate Joint 2 to the home position and ensure that all joint screws are visible.

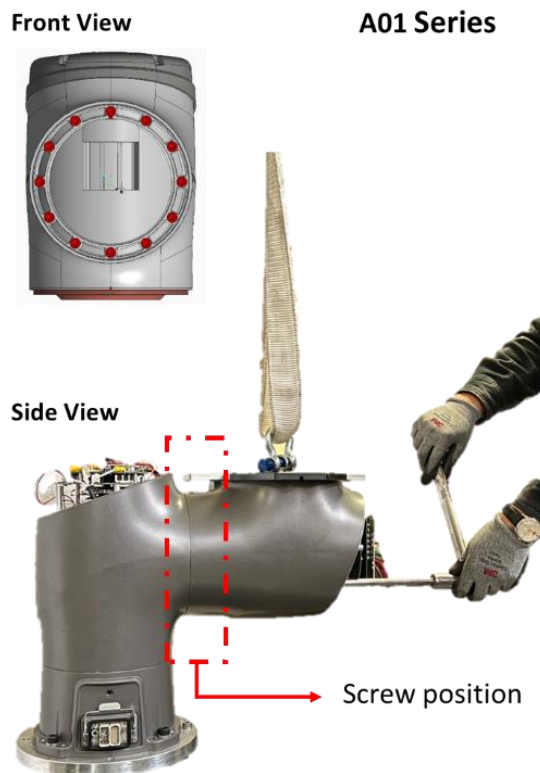

6.8.1 Remove the Joint Cover of Joint 2.

6.8.2 Remove the Joint cable of Joint 2.

6.8.3 Install the jig, secure the lifting rope to the auxiliary tool, and adjust the lifting rope slightly tight to prevent the Joint from tilting in other directions after the Joint connection screws are removed.

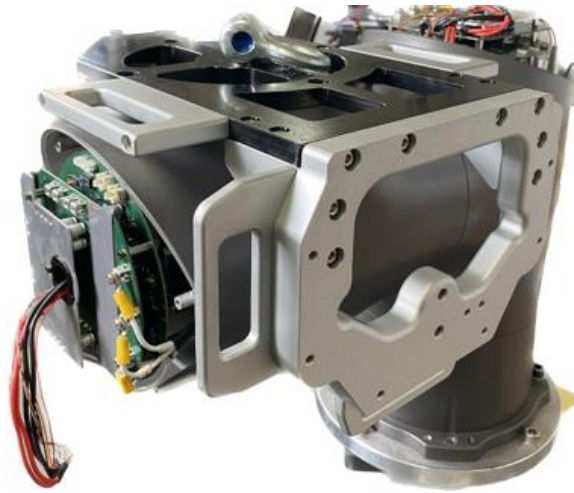

6.8.1 Remove the connecting screws between Joint 2 and Joint 1, and take off Joint.

6.8.2 When assembling Joint 2, align the Key and Slot of the A01 Series Joint in the figure below and follow the previous steps in reverse. °



Caution: When assembling the A01 series joints, make sure that the A01 series joint key is securely attached to the slot to prevent abnormal operation of the arm controller or unexpected errors

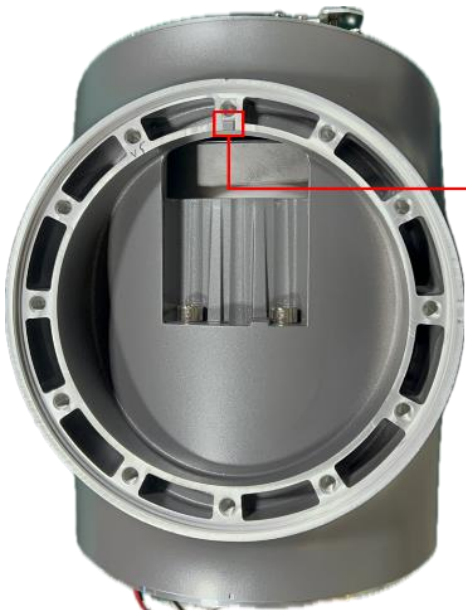

A01 Series Joint Screw Side

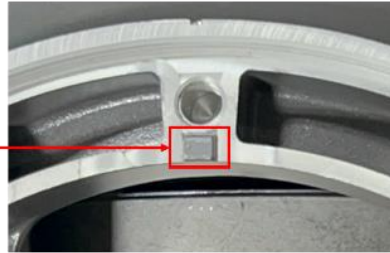

A01 Series Key Slot

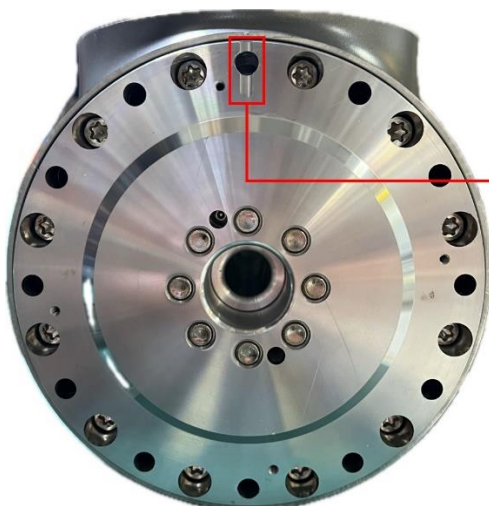

A01 Series Joint Flange Side

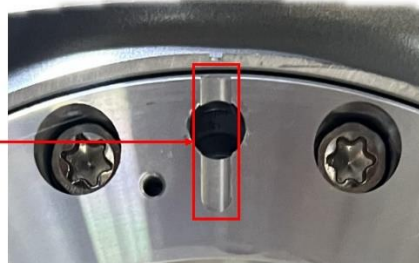

A01 Series Flange Slot

6.9 Disassembly and assembly 800 Series Joint

6.9.1 Remove the Joint cover and Joint rubber.

6.9.2 Remove the Joint cable from the Joint.

6.9.3 Remove the screws connecting the Joint to other Joints or the Arm, then detach the Joint.

6.9.4 During assembly, follow the reverse steps of the previously mentioned procedure.

6.10 Disassembly and assembly 500 Series Joint

6.10.1 Remove the Joint cover and Joint rubber.

6.10.2 Remove the Joint cable from the Joint.

6.10.3 Remove the screws connecting the Joint to other Joints or the Arm, then detach the Joint.

6.10.4 During assembly, follow the reverse steps of the previously mentioned procedure.

6.11 Disassembly and assembly 200L Series Joint

6.11.1 Remove the Joint cover and Joint rubber.

6.11.2 Remove the Joint cable from the Joint.

6.11.3 Remove the screws connecting the Joint to other Joints or the Arm, then detach the Joint.

6.11.4 During assembly, follow the reverse steps of the previously mentioned procedure.

6.12 Disassembly and assembly Upper arm

6.12.1 Remove Joint cover and Joint rubber which in Joint 2 & Joint 3

6.12.2 Remove Joint cable which in Joint 2 & Joint 3

6.12.3 Remove the screws connecting the Upper arm to Joint 2 and Joint 3, then detach the Upper arm.

6.12.4 (Please refer Arm figure below) After removing the Upper arm, use needle-nose pliers to compress the bracket at location A, then extract the bracket from the groove. Next, remove the wiring and plastic bushing at location B.

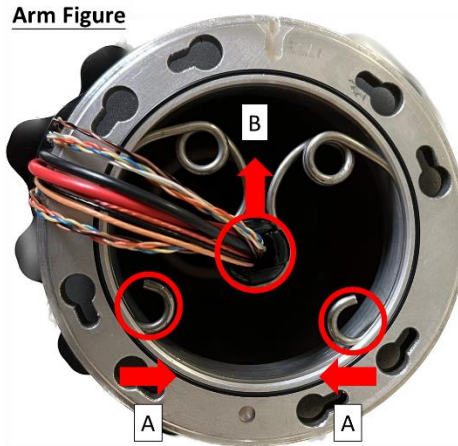

6.12.5 During Upper assembly, follow the reverse steps of the previously mentioned procedure.

6.12.6 When replacing the MII cable, camera cable, and S48V cable from Joint 2 to Joint 3, there is no need to disassemble the Arm tube. You can directly insert the new cables from Joint 3 and pull them out from Joint 2. For the old cables, trim the connectors at both ends and pull them out.

6.12.7 When inserting the new cables, apart from the power cable, the other cables (MII cable, camera cable, S48V cable) do not need to be tied inside the metal ring. However, it is necessary to use acetic acid cloth to secure the new cables.

6.13 Disassembly and assembly Lower arm

6.13.1 Remove Joint cover and Joint rubber which in Joint 4 & Joint 5

6.13.2 Remove Joint cable which in Joint 4 & Joint 5

6.13.3 Remove the screws connecting the Lower arm to Joint 2 and Joint 3, then detach the Upper arm.

6.13.4 (Please refer Arm figure below) After removing the Upper arm, use needle-nose pliers to compress the bracket at location A, then extract the bracket from the groove. Next, remove the wiring and plastic bushing at location B.

Arm Figure

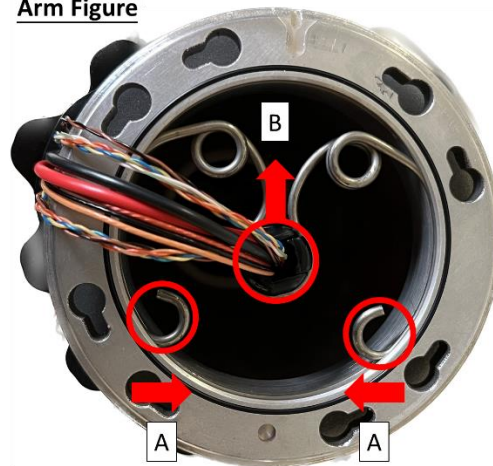

6.13.5 During Lower arm assembly, follow the reverse steps of the previously mentioned procedure.

6.13.6 When replacing the MII cable, camera cable, and S48V cable from Joint 4 to Joint 5, there is no need to disassemble the Arm tube. You can directly insert the new cables from Joint 5 and pull them out from Joint 4. For the old cables, trim the connectors at both ends and pull them out.

6.13.7 When inserting the new cables, apart from the power cable, the other cables (MII cable, camera cable, S48V cable) do not need to be tied inside the metal ring. However, it is necessary to use acetic acid cloth to secure the new cables.

6.14 Disassembly and assembly End module

6.14.1 Remove Joint cover and Joint rubber which in Joint 6

6.14.2 Remove Joint cable which in Joint 6.

6.14.3 Remove the connecting screws between Joint 6 and the End module, then detach the End module.

6.14.4 During assembly, follow the reverse steps of the previously mentioned procedure.

6.15 Disassembly and assembly Light module

6.15.1 Refer to the picture below to remove the four screws securing the camera light source module.



6.15.1 Unplug the power cable of the light source module and remove the light source module, being careful not to let the O-ring fall off.



6.15.2 During the assembly of the End module, please follow the reverse steps of the previously mentioned procedure.

6.16 Disassembly and assembly Camera module

6.16.1 Loosen the three M3L10 screws on the camera module, separate the camera module casing from the End module. The torque during assembly is 10 kgf-cm.

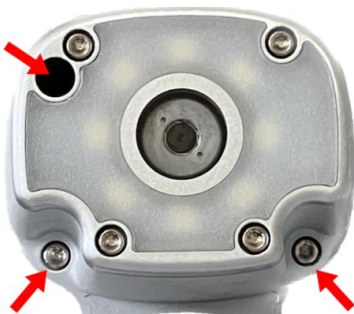

6.16.2 Disconnect the cables as shown in the below.

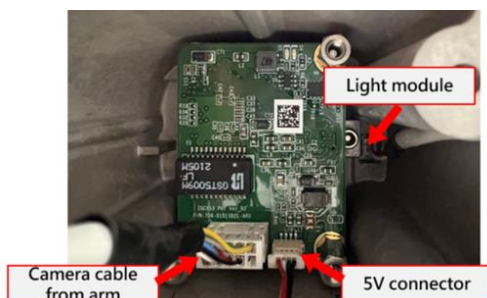

Hardware Version : 5.02 Document Version : 0

TECHMAN ROBOT INC. 5F., No. 58-2, Huaya 2nd Rd., Guishan Dist., Taoyuan City, 333411, Taiwan

6.16.1 After removing the camera module, take off the three M3L6 screws securing the TRI camera. The torque during assembly is 10 kgf·cm



6.16.1 After removing the TRI camera unit (refer to the below picture), replace it directly with a new TRI camera. Do not perform any disassembly or modifications on the components of the unit.

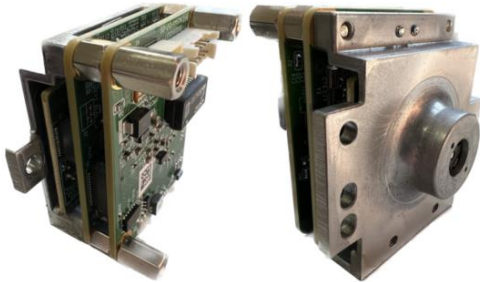

6.16.2 When assembling the camera, please follow the reverse steps of the previously mentioned procedure.

6.17 DIP Switch Setting

6.17.1 After replacing or rearranging Joints, use pliers to move the Joint DIP switch to the corresponding position according to the following specifications:

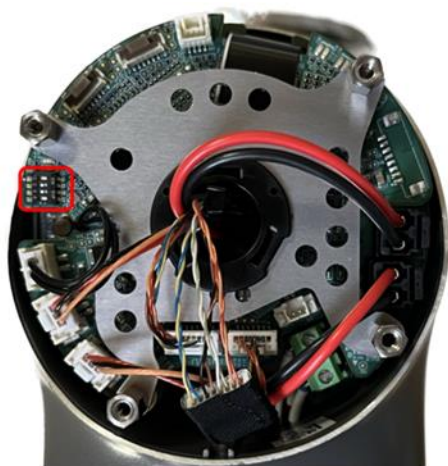

200L Series Joint

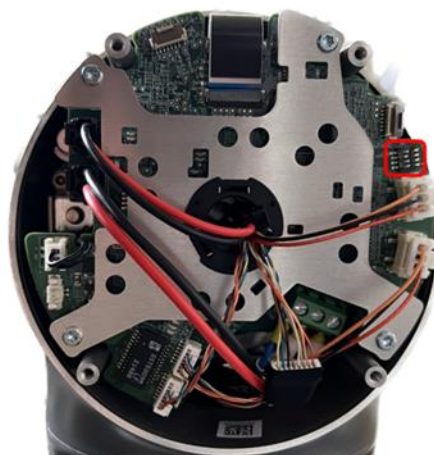

500 Series Joint

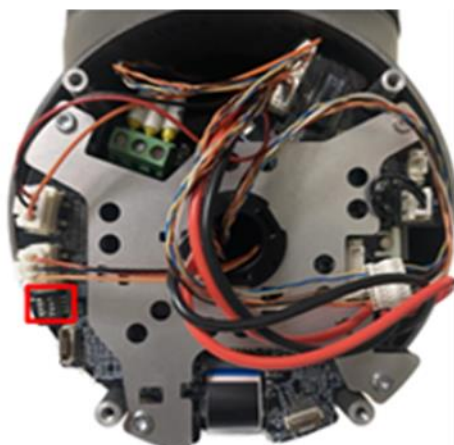

800 Series Joint

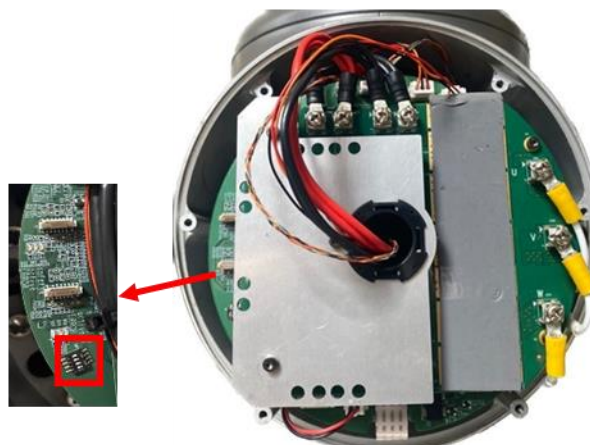

A01 Series Joint

J1		ON					J4		ON				
	H							H					
	L							L					
		1	2	3	4			1	2	3	4		
J2		ON					J5		ON				
	H							H					
	L							L					
		1	2	3	4			1	2	3	4		
J3		ON					J6		ON				
	H							H					
	L							L					
		1	2	3	4			1	2	3	4		



CAUTION: Failure to set the DIP switch on the Joint to the specified position may trigger Error Code 0x0000004E or other unexpected errors.

6.18 Software Update

6.18.1 After replacing the hardware components, perform the relevant software updates and calibrations according to the chart below.

✓	Need to be done										
✗	No need to be done										
	Software updating			Calibration							TMFlow
	Reinstall RobotId	ESI	FW	Hand Guide	Dynamic	Vision	Kinematics	Hand-Eye	Barcode	Trial run	Save Safety Setting
Joint	✗	✓	✓	✓	✓	✗	✓	✓	✓	✓	✗
End Module	✓	✓	✓	✓	✓	✓	✓	✓	✓	✓	✗
Camera	✗	✗	✗	✗	✗	✓	✓	✓	✓	✓	✗
Patriot Power Board	✓	✓	✓	✗	✗	✗	✗	✗	✗	✗	✓

✗ Whenever doing which Kind of Calibration. Calibration data needs to be saved after the calibration is completed to avoid unexpected errors.

6.18.2 **Accessing Windows:** In the powered-off state, press the emergency stop switch and install the Maintenance Dongle on the control box. After turning on, an error code will be displayed on the TM Flow screen due to the emergency stop switch cutting off the power between the control box and the robot. Click Exit in the bottom left corner of the screen to enter Windows.



Note: After entering Windows, be sure to release the emergency stop switch. After releasing the emergency stop switch, check if the End module indicator lights are flashing. If the indicator lights are not flashing, it means the control box is not correctly connected to the arm. Do not proceed with the subsequent steps and prioritize troubleshooting.

6.18.3 **ReinstallRobotId:** After entering Windows, execute the file "ReinstallRobotId" in the path "D:\Techman Robot\TM Flow\ModuleRelease". After completion, it is necessary to completely turn off the power to the control box and the robot before restarting. It is recommended to unplug the external power cord after shutdown and then reconnect it before turning the power back on, ensuring a complete power shutdown.

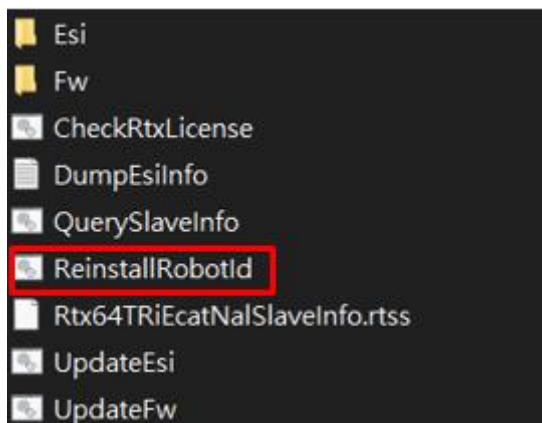

6.18.4 **UpdateEsi:** After entering Windows, execute the file "UpdateEsi" in the path "D:\Techman Robot\TM Flow\ModuleRelease". After completion, it is necessary to completely turn off the power to the control box and the robot before restarting. It is recommended to unplug the external power cord after shutdown and then reconnect it before turning the power back on, ensuring a complete power shutdown.

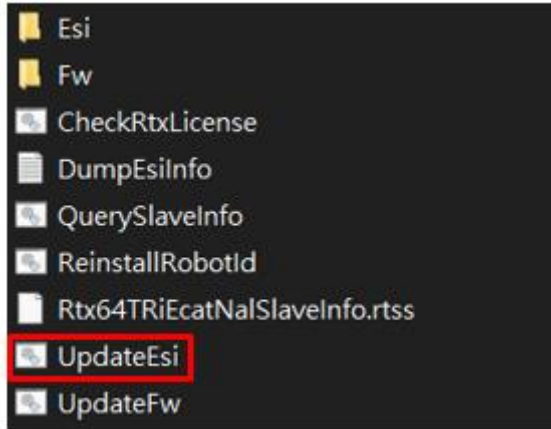

6.18.5 **UpdateFW:** After entering Windows, execute the file "UpdateFW" in the path "D:\Techman Robot\TM Flow\ModuleRelease". After completion, it is necessary to completely turn off the power to the control box and the robot before restarting. It is recommended to unplug the external power cord after shutdown and then reconnect it before turning the power back on, ensuring a complete power shutdown.

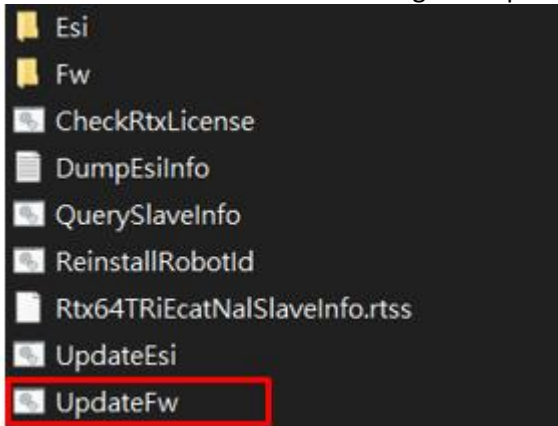

6.18.6 After replacing new joints and the Patriot power board, the robot may display the following screen during boot-up. This indicates that the joint serial number has changed. Select "OK" and enter the default password "00000000". The robot will then shut down and reboot automatically.

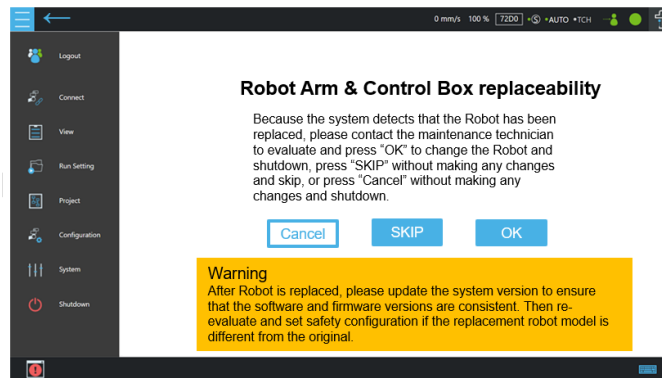

6.18.7 When replacing a new end module or its PCBA, user needs to go to maintenance mode and perform the following steps:

1. Go to 'Maintenance mode', select 'Safety'
2. Enter 00000000 and select Login, and then press 'OK'

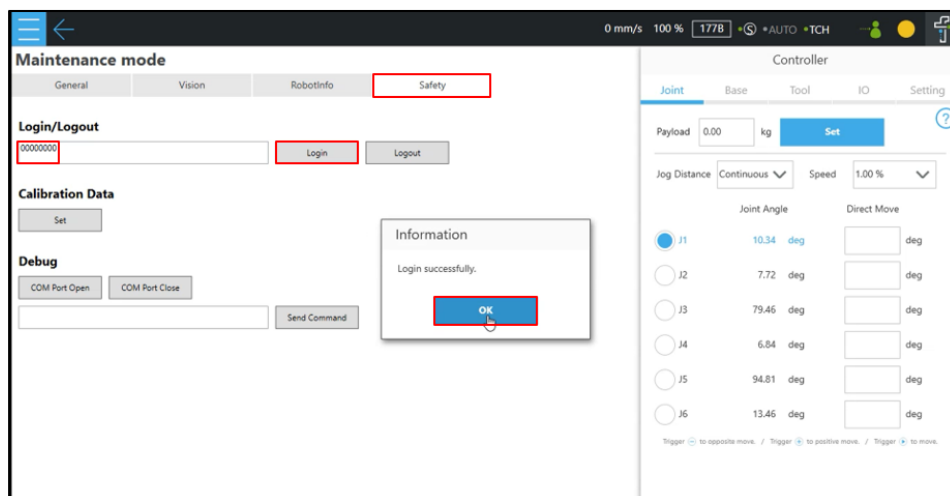

1. Press 'Set' to upload the calibration data from control box to arm
2. Press 'OK' and the TMflow will shut down automatically

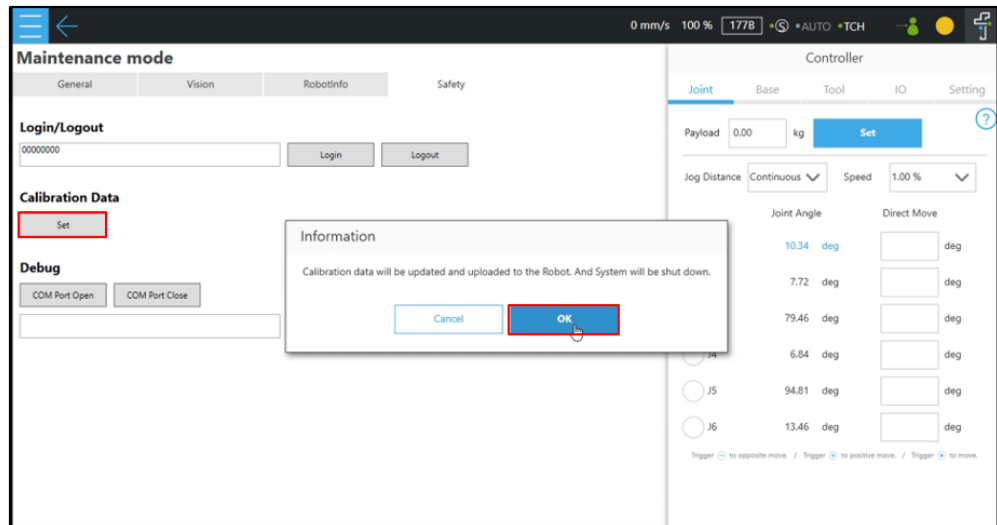

7. Control Box Disassembly / Assembly Control Box

7.1 Quick maintenance guide

7.1.1 To ensure operational safety, at least two persons are required to collaborate in the disassembly process.

7.1.2 Before disassembly, place the control box on a soft surface (such as a blanket or sponge pad) for disassembly.

7.1.3 Before disassembly, take photos to record the status and wiring configuration. These photos will serve as reference points during the reassembly process.

7.1.4 Follow the right-hand rule when disassembling and installing screws.

7.1.5 When installing components, use a torque wrench to tighten the parts according to the torque specifications table below:

Torque specifications for Control board		
Item	torque value(Kgf.cm)	torque value(Nm)
IPC	6	0.6
Patriot power board	6	0.6
Relay board	6	0.6
Power eater board	6	0.6
PSU cable	10	0.98
PSU Bracket	14	1.37
SSD Bracket	14	1.37

7.2 Open the Control Box Outer Casing

7.2.1 Before opening the outer casing of the control box, ensure that the control box is completely powered off, and disconnect the external power cord and robot cable.

7.2.2 Open the outer casing cover of the control box, loosen the four inner casing screws, and open the inner casing cover.

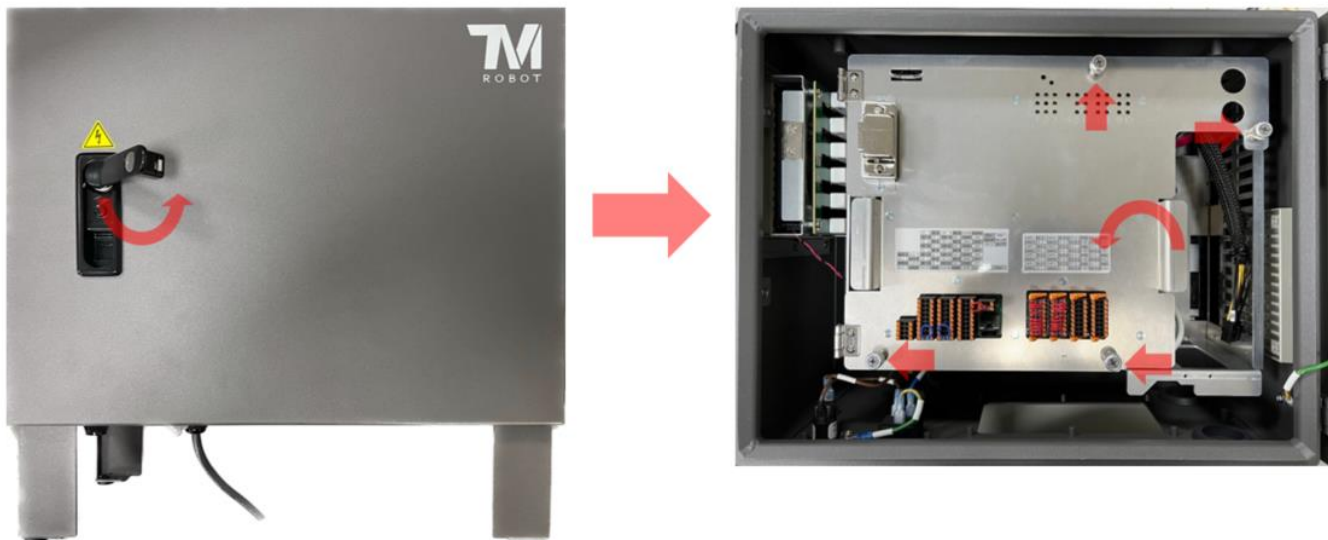

7.3 Disassembly/Assembly of IPC

7.3.1 Refer to "Open the Control Box Outer Casing" to open the outer casing cover and inner casing cover.

7.3.2 Refer to the diagram below to remove the connectors, and if necessary, cut cable ties.

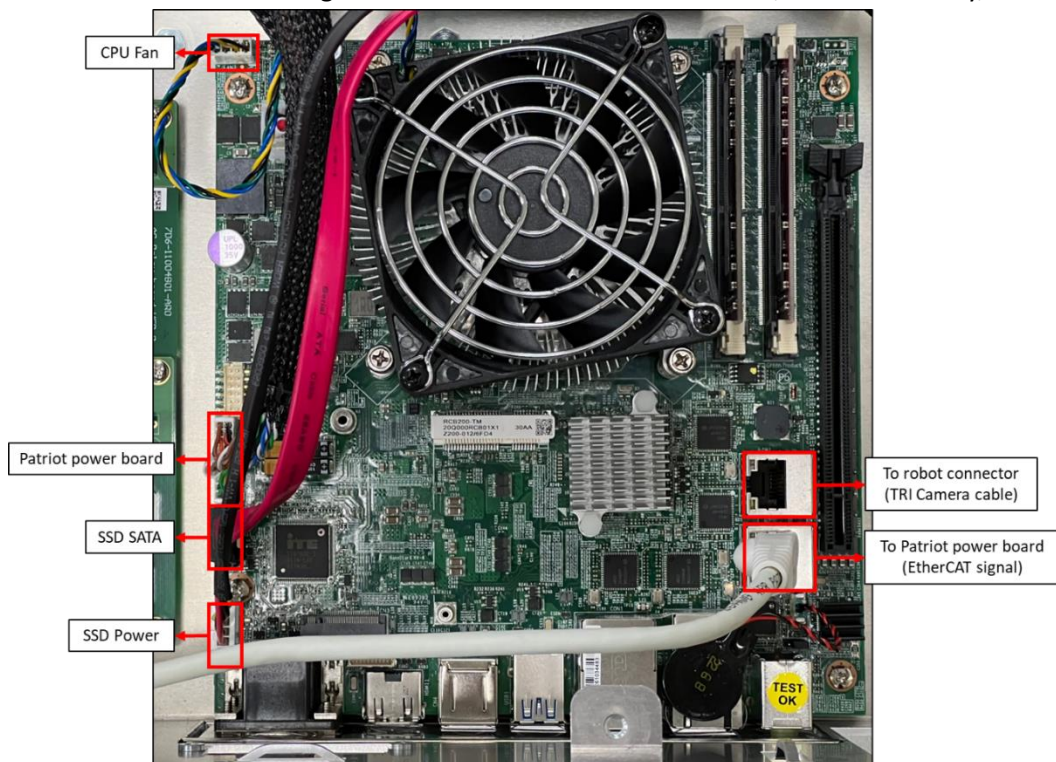

7.3.1 Loosen the four screws securing the IPC.

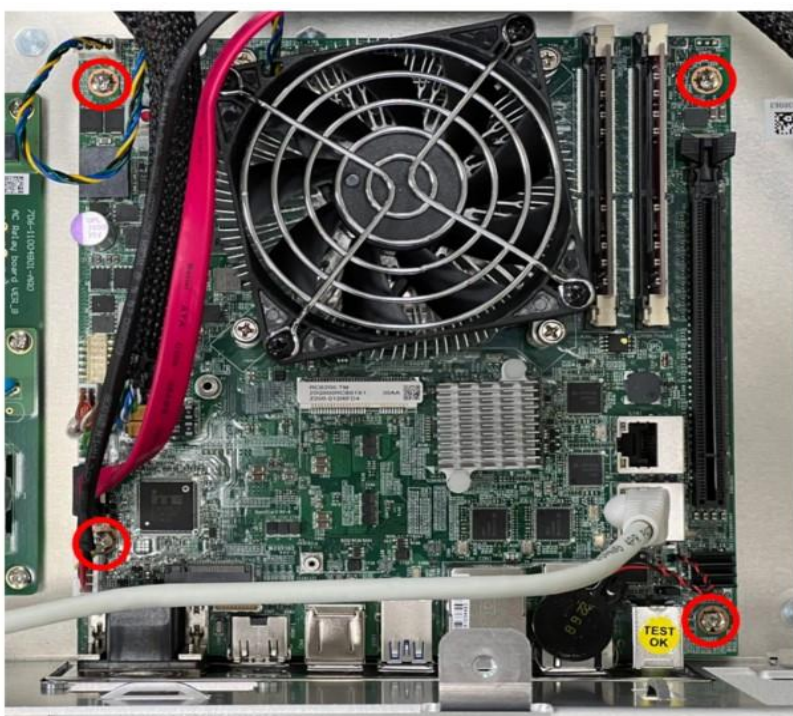

7.3.1 During installation, follow the reverse steps of the above procedure. If cable ties were cut, secure the wires again in the original manner.

7.4 Disassembly/Assembly of the Patriot Power Board



Caution: Replacing the Patriot power board will reset the Safety settings in the TM flow, please refer to the Safety settings section in the software manual for saving and recovery.

7.4.1 Refer to "Open the Control Box Outer Casing" to open the outer casing cover and inner casing cover.

7.4.2 Refer to the diagram below to remove the connectors, and if necessary, cut cable ties:

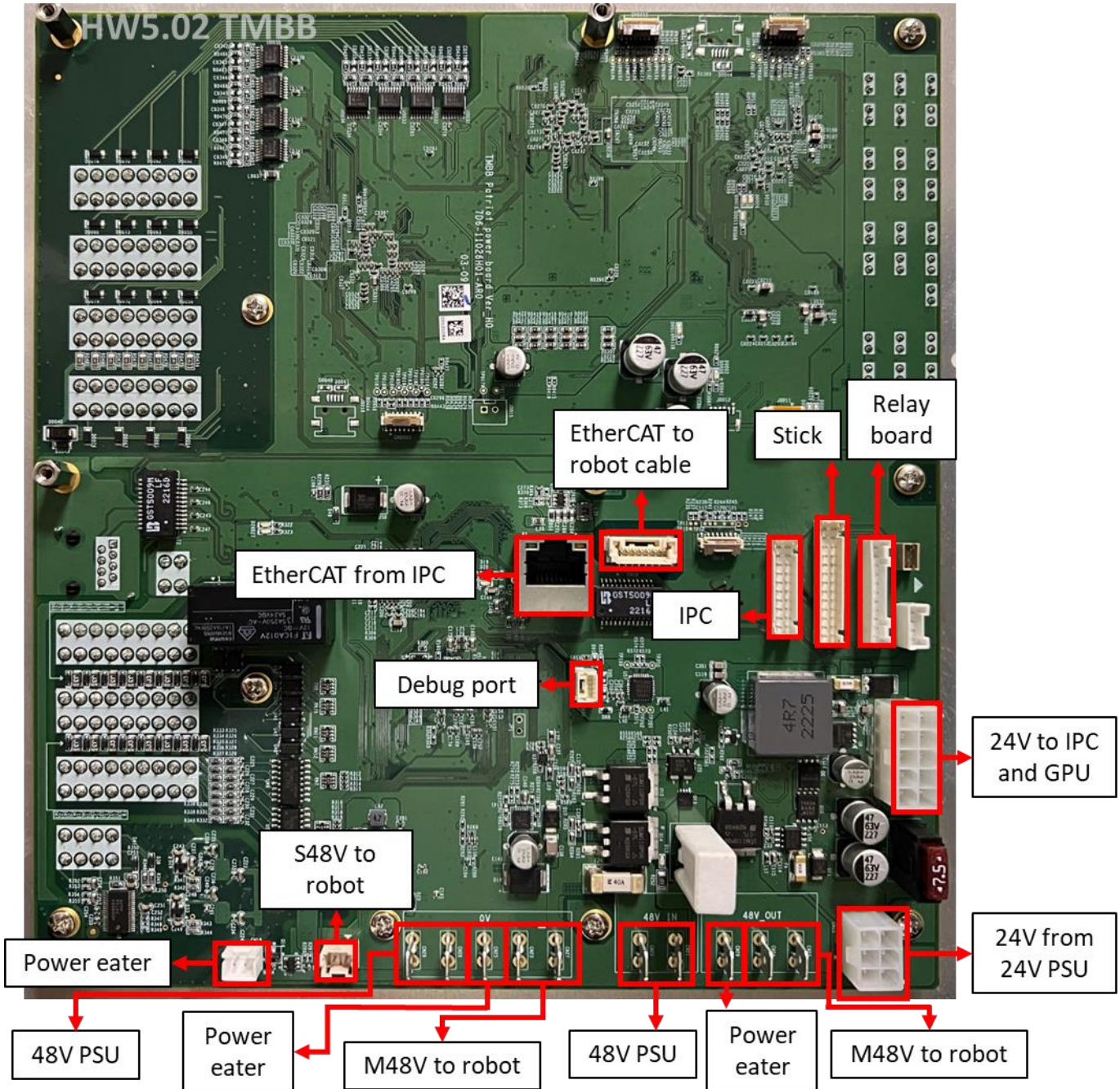

Hardware Version : 5.02 Document Version : 0

TECHMAN ROBOT INC. 5F., No. 58-2, Huaya 2nd Rd., Guishan Dist., Taoyuan City, 333411, Taiwan

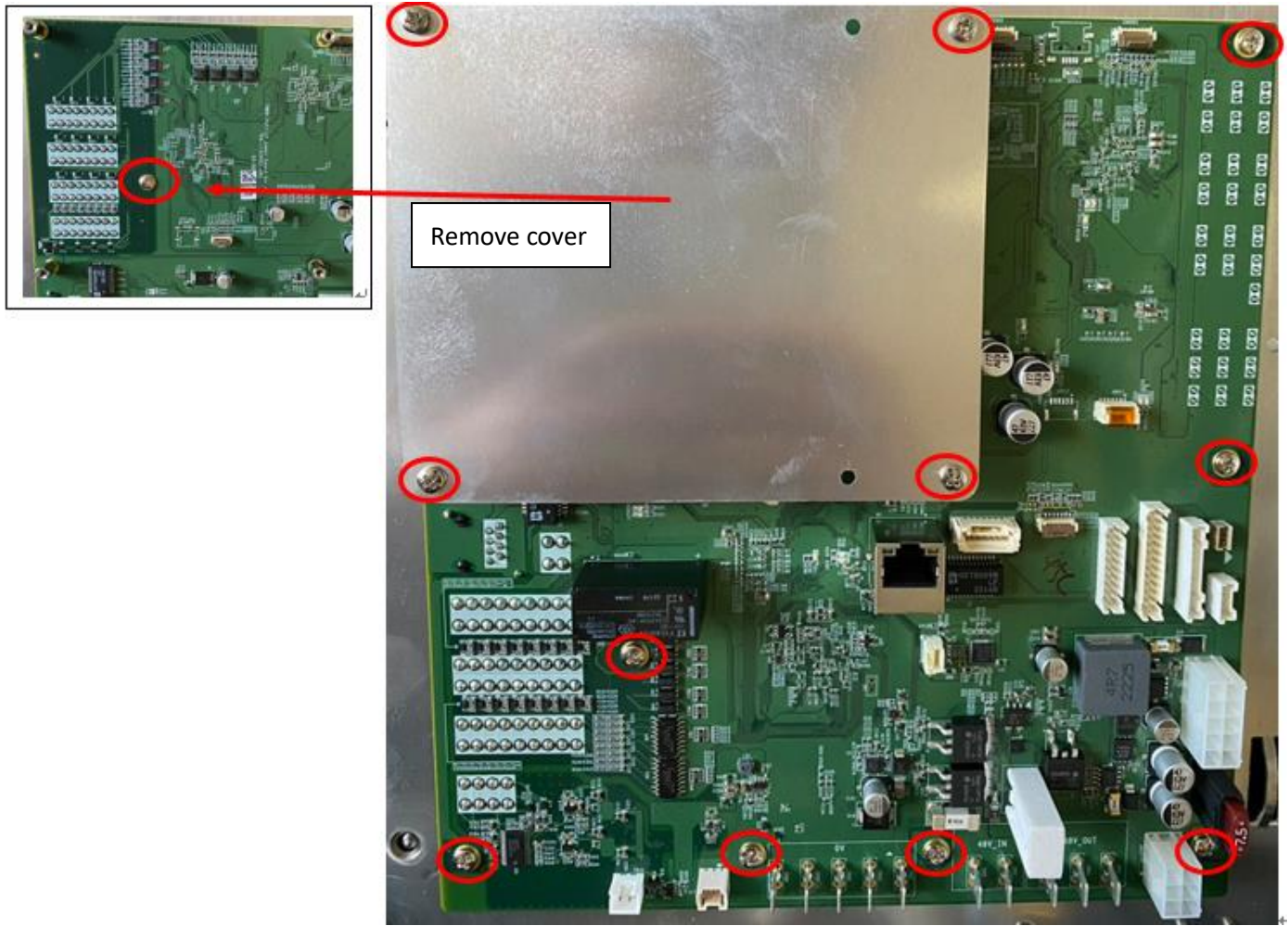

7.4.3 Loosen the 12 screws securing the Patriot Power Board.

7.4.4 During installation, follow the reverse steps of the above procedure. If cable ties were cut, secure the wires again in the original manner

7.5 Disassembly/Assembly Relay board

7.5.1 Refer to "Open the Control Box Outer Casing" to open the outer casing cover and inner casing cover.

7.5.2 Refer to the diagram below to remove the connectors, and if necessary, cut cable ties

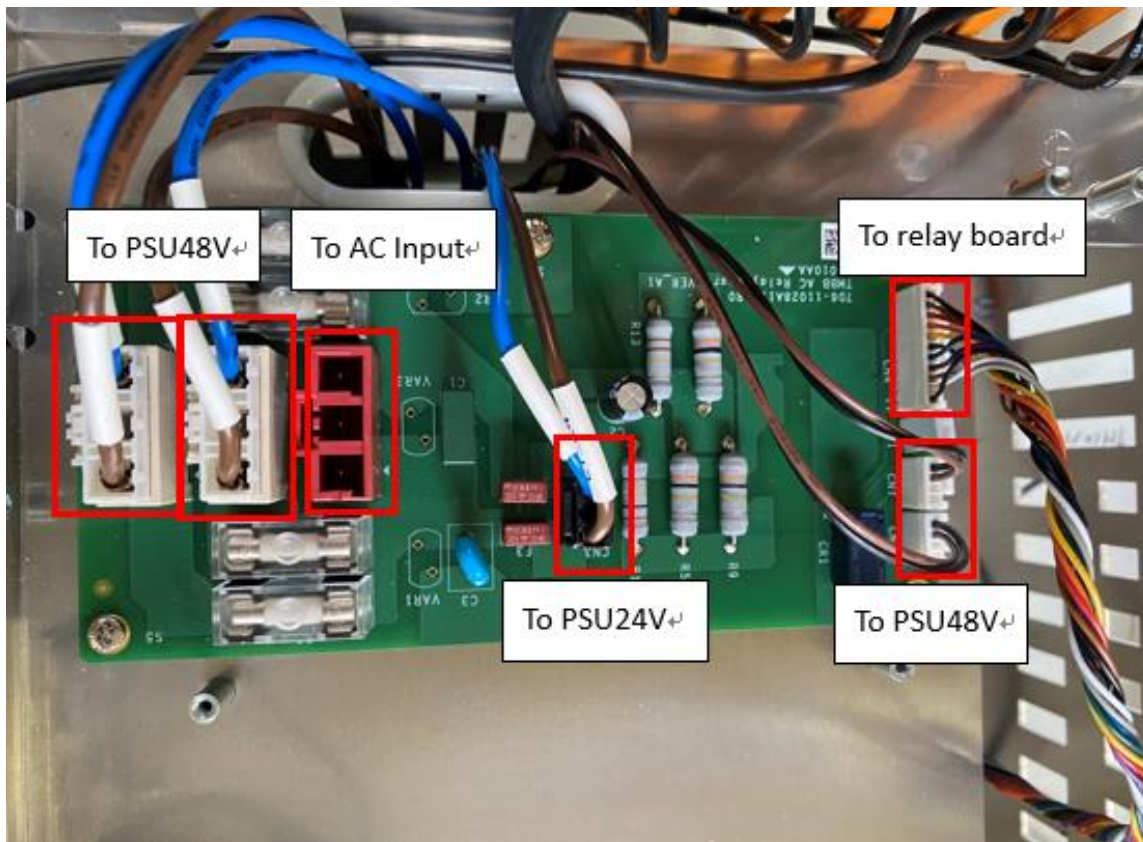

7.5.3 Loosen the 6 screws securing the Relay Board.

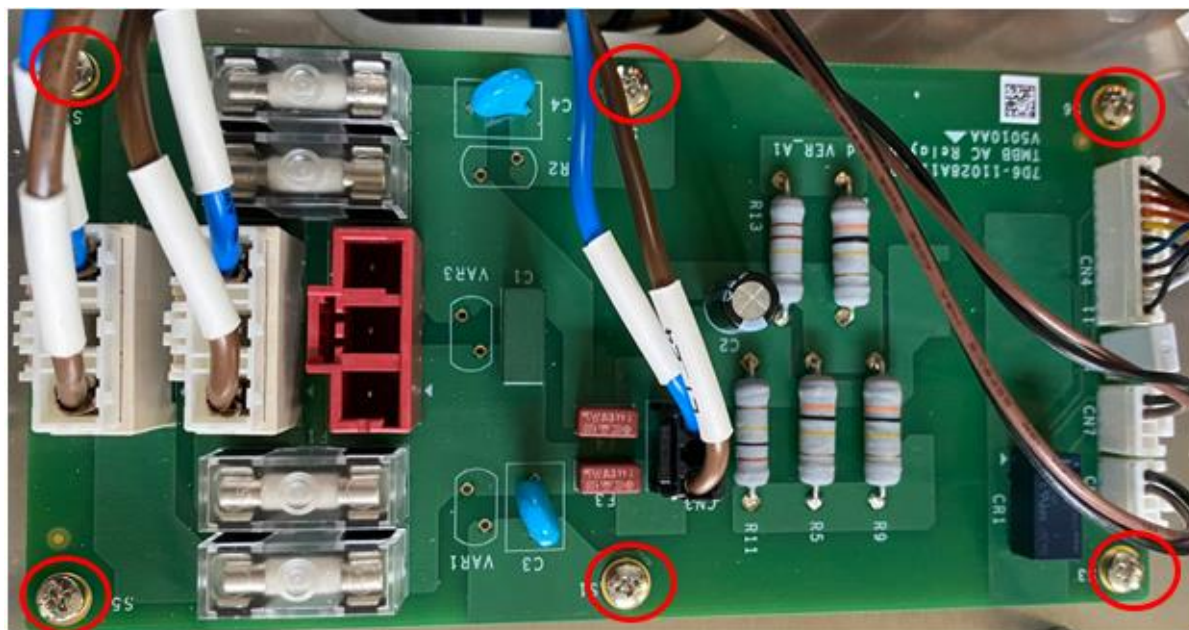

7.5.1 During installation, follow the reverse steps of the above procedure. If cable ties were cut, secure the wires again in the original manner

7.6 Disassembly/Assembly Stick

7.6.1 Refer to "Open the Control Box Outer Casing" to open the outer casing cover and inner casing cover

7.6.2 Refer to the diagram below to remove the Stick connector, and if necessary, cut cable ties:

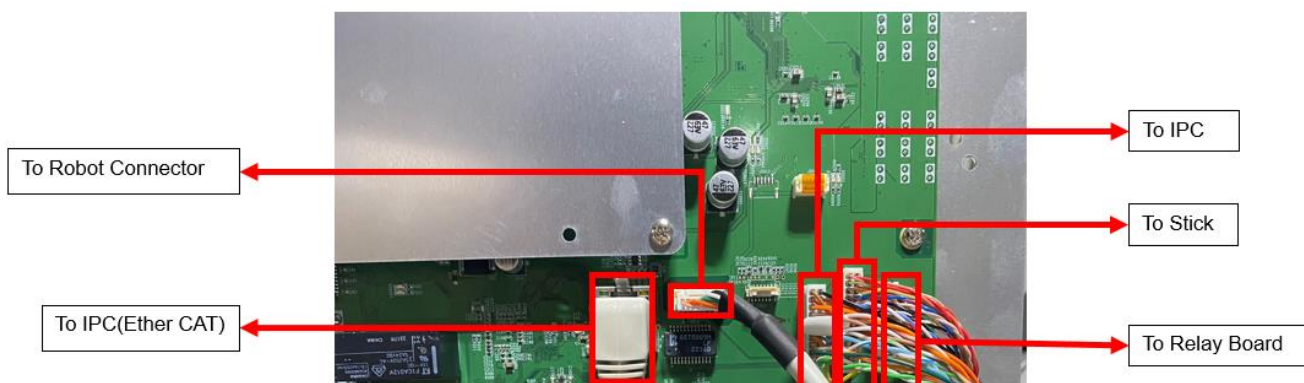

7.6.1 Refer to the diagram to sequentially loosen Stick securing nut A and wire securing nut B:

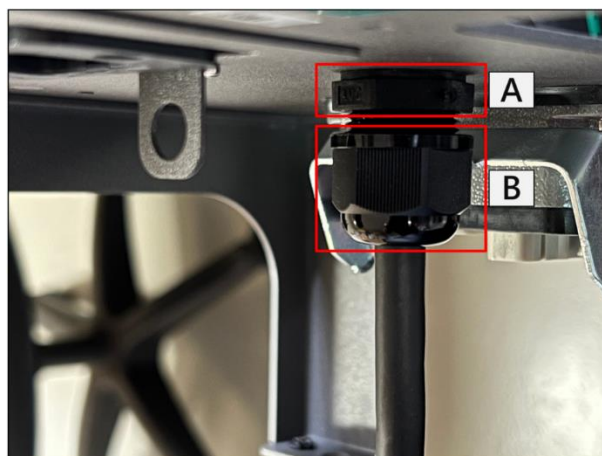

7.6.2 Refer to the diagram to gently bend the Stick connector slightly, and sequentially thread it through the Stick securing nut (Figure A) and the control box (Figure B) to remove the Stick.

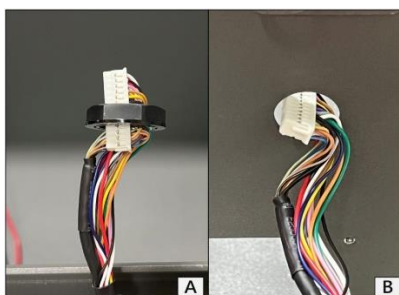

7.6.1 During installation, follow the reverse steps of the above procedure. If cable ties were cut, secure the wires again in the original manner

7.7 Disassembly/Assembly of Robot Connector and Internal Composite Cable

- 7.7.1 Refer to "Open the Control Box Outer Casing" to open the outer casing cover and inner casing cover
- 7.7.2 Refer to "Disassembly/Assembly Patriot power board" to remove" Robot connector (Servo 48V)"
- 7.7.3 Refer to "Disassembly/Assembly Patriot power board" to remove" Robot connector (Motor 48V)".
- 7.7.4 Refer to "Disassembly/Assembly Patriot power board" to remove" Robot connector (EtherCAT).
- 7.7.5 Refer to "Disassembly/Assembly IPC" to remove" Robot connector (Camera).
- 7.7.6 Remove the grounding wire as shown in the diagram below.



- 7.7.7 Remove the four Robot connector screws shown in the diagram and take out the internal composite cable

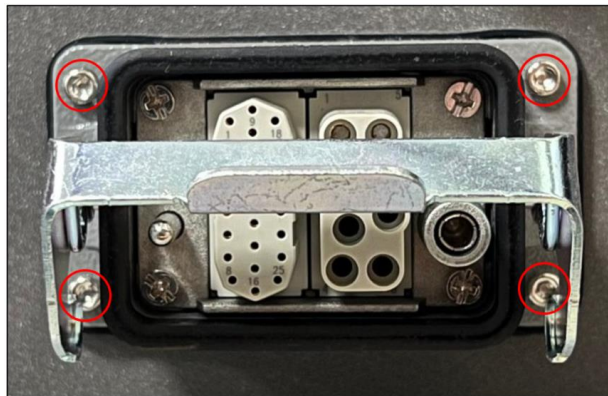

- 7.7.8 During installation, follow the reverse steps of the above procedure. If cable ties were cut, secure the wires again in the original manner

7.8 Disassembly/Assembly of Inner Casing

7.8.1 Refer to "Open the Control Box Outer Casing" to open the outer casing cover and inner casing cover

7.8.2 Refer to "Disassembly/Assembly of Robot Connector and Internal Composite Cable" to remove the Robot connector and internal composite cable.

7.8.3 Refer to "Disassembly/Assembly of the Patriot Power Board" to remove the "To Power eater board B" connector.

7.8.4 Refer to "Disassembly/Assembly of the Patriot Power Board" to remove the "To Power eater board B" connector.

7.8.5 Refer to "Disassembly/Assembly of the Patriot Power Board" to remove the "To Control box fan" connector.

7.8.6 Refer to "Disassembly/Assembly of the Relay Board" to remove the "From external power (AC IN)" connector.

7.8.7 Refer to the diagram below to remove the 7 inner casing securing nuts and take out the inner casing.

7.8.8 During installation, follow the reverse steps of the above procedure. If cable ties were cut, secure the wires again in the original manner

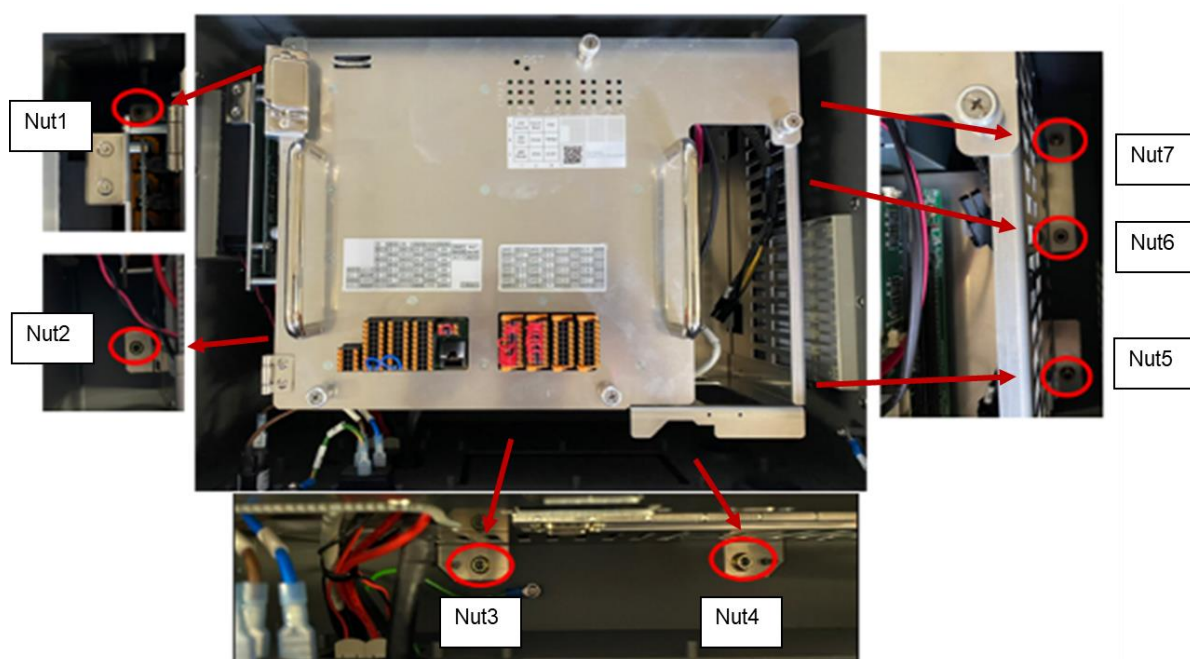

7.9 Disassembly/Assembly Power eater board

7.9.1 Refer to "Disassembly/Assembly of Inner Casing" to remove the inner casing

7.9.2 Refer to the diagram below to remove the connectors "To Patriot power board A" and "To Patriot power board B". After removing the four securing screws, take out the Power Eater Board.

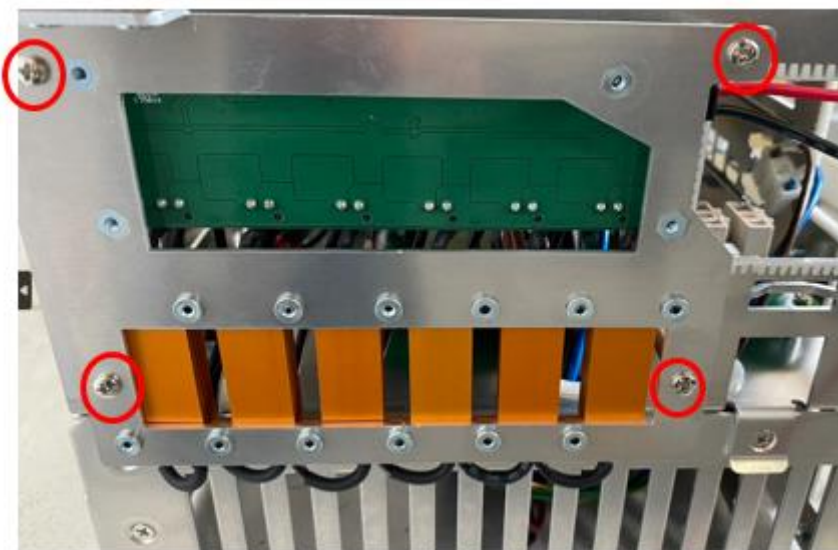

7.9.3 During installation, follow the reverse steps of the above procedure. If cable ties were cut, secure the wires again in the original manner.

7.10 Disassembly/Assembly of 48V PSU (Two 48V PSU inside the TM25S control box)

7.10.1 Refer to "Disassembly/Assembly of Inner Casing" to remove the inner casing.

7.10.2 Refer to the diagram below to disconnect the wiring.

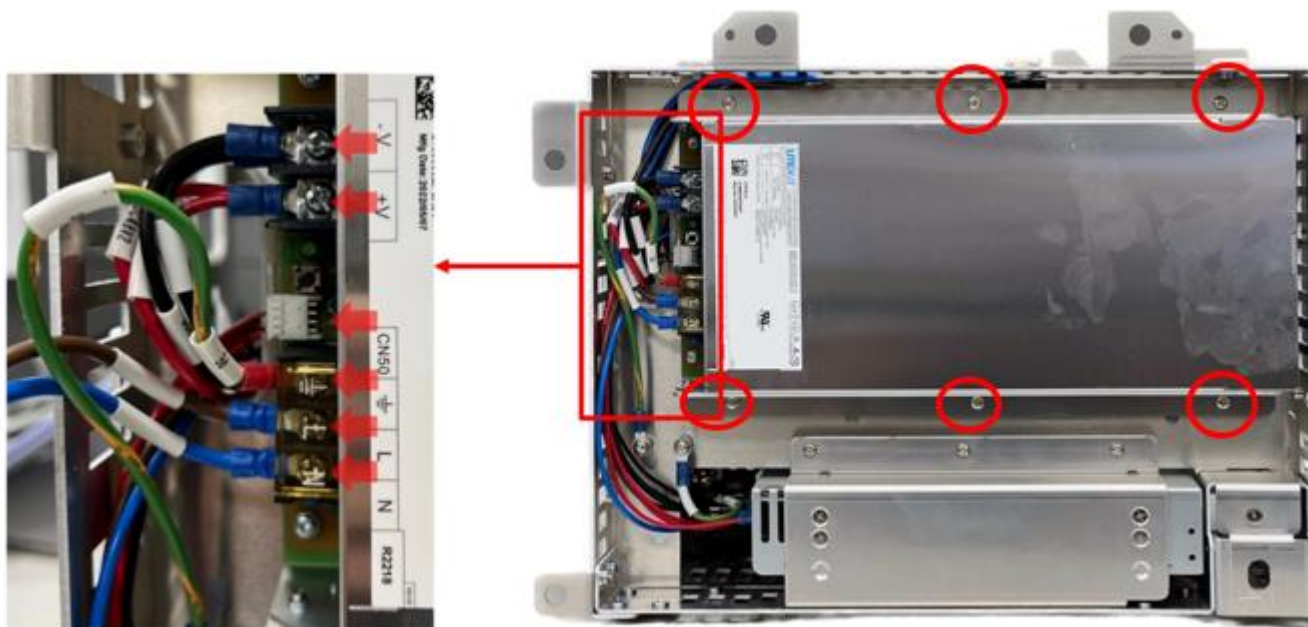

7.10.1 Refer to the diagram below to remove the six securing screws and take out the 48V PSU with the bracket.

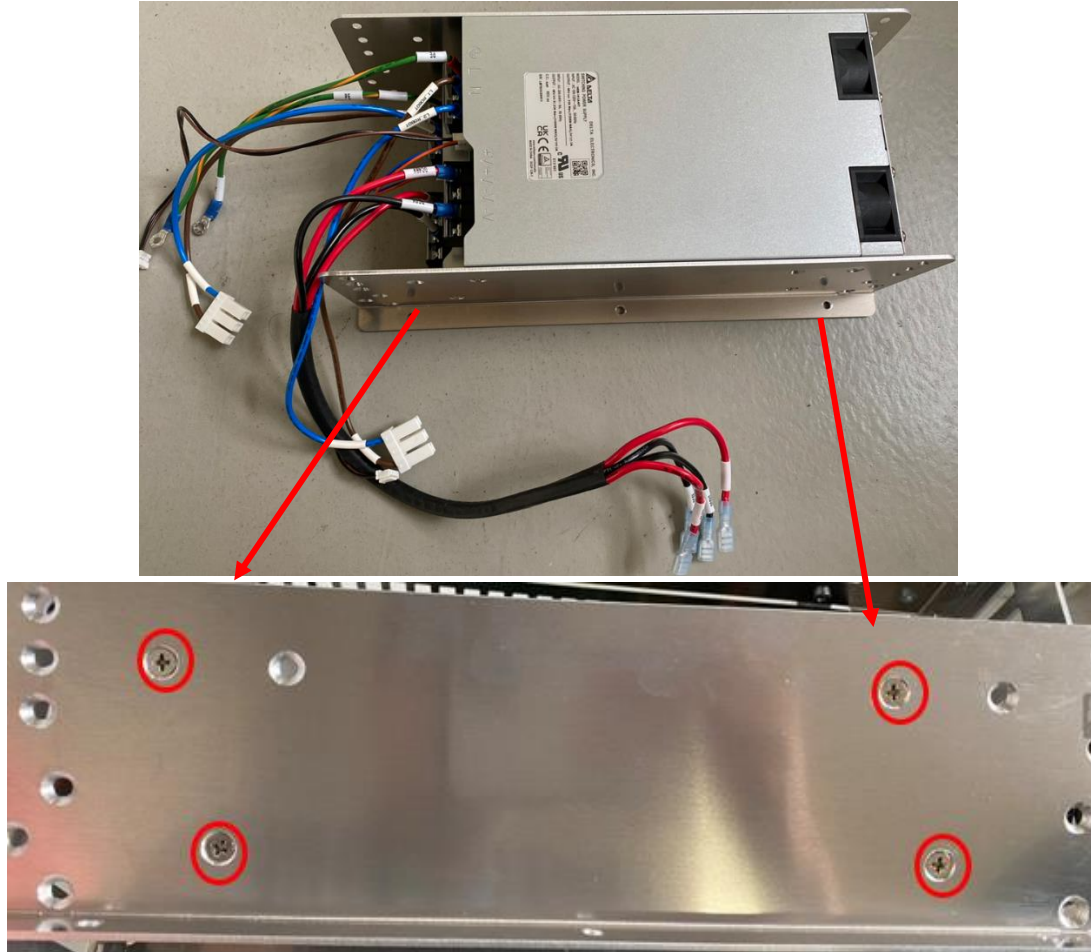

7.10.2 Refer to the diagram above to remove the four securing screws and take out the 48V PSU with the bracket.

7.10.3 During installation, reverse the above steps. If cable ties were cut, reattach the cables using the original securing method.

7.11 Disassembly/Assembly 24V PSU

7.11.1 Refer to "Disassembly/Assembly of Inner Casing" to remove the inner casing.

7.11.2 Refer to the diagram below to remove the two securing screws.



7.11.1 Refer to the diagram below to remove the four securing screws and one grounding wire screw.

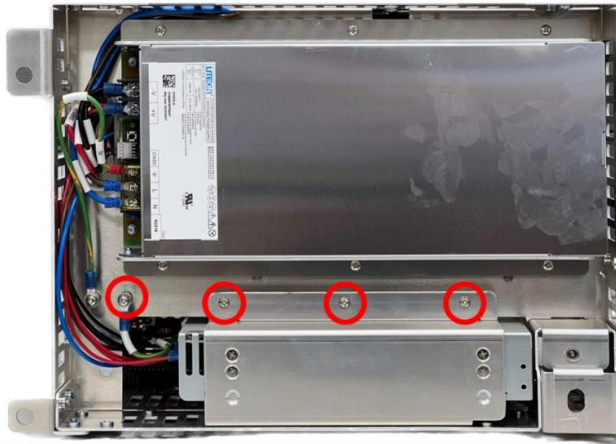

7.11.1 Refer to the diagram below to disconnect the wiring and take out the 24V PSU with the bracket.



7.11.1 Refer to the diagram below to remove the six bracket securing screws and take out the 24V PSU.



7.11.2 During installation, follow the reverse steps of the above procedure. If cable ties were cut, secure the wires again in the original manner

7.12 Disassembly/Assembly of Filter

7.12.1 Slide the tray upward along the tray slide to remove it

7.12.2 Remove the filter and replace it with a new one.



7.12.3 Reinstall the tray.

8. Indication Light

8.1 Power board Light Indication

LED Position



LED Position Corresponding Function

A	24V Source	Heart-beat	PW!
B	48V PSU	Error	Temp!
C	48V Mode	STO!	ECAT!
	1	2	3

LED Position	LED Name	LED Status Description
A1	24V Source	Off = External 24V
		On = Internal 24V
		100ms/100ms Rapid Blink = Internal 24V Error
		500ms/500ms Blink = Internal 24V Current Exceeded
B1	48V PSU	Off = PSU off
		On = (Reserved)
		500ms/500ms Blink = PSU on
C1	48V Mode	Off = 48V off
		On = Normal Mode
		500ms/500ms Blink = Limit Mode
A2	HeartBeart	Off = FW Stuck or Abnormal Protection Pause
		On = FW Stuck
		500ms/500ms Blink = Running
B2	Error	Off = Normal
		100ms/100ms Rapid Blink = ESC Not Ready
		500ms/500ms Blink = Abnormal Protection Pause
		Coding = Error code (Reserved)
C2	STO Alarm	Off = Normal
		On = STO (ESM<OP)
		100ms/100ms Rapid Blink = STO (Low Voltage)
		500ms/500ms Blink = STO (Patriot Act.)
A3	Power Alarm	Off = Normal
		On = 48V & 24V Warning
		100ms/100ms Rapid Blink = 48V Warning

Hardware Version : 5.02 Document Version : 0

TECHMAN ROBOT INC. 5F., No. 58-2, Huaya 2nd Rd., Guishan Dist., Taoyuan City, 333411, Taiwan

LED Position	LED Name	LED Status Description
		500ms/500ms Blink = 24V Warning
B3	Temperature Alarm	Off = Normal
		On = PCB & Eater Warning
		100ms/100ms Rapid Blink = PCB Warning
		500ms/500ms Blink = Eater Warning
C3	EtherCAT Alarm	Off = Normal
		On = Packet Loss Warning
		100ms/100ms Rapid Blink = InvalidFrame or RxErr or PUErr counted
		500ms/500ms Blink = PDIErr counted
		1000ms/1000ms Slow Blink = Forwarded RxERR counted

8.2 End module Indication Light Ring

8.2.1 Special Light Indication

Initializing:	Alternating between Red and Light Off equally
Power On with STO status:	Failed to finish booting up and Light Off (Buzzer no beep)
Power On with SOS status:	Finished booting up and the light indicated as the tables below.
Robot in STO status:	Light Off (Buzzer no beep)
Robot in SOS status:	Light indicated as the tables below.
Updating:	Alternating between Red and Light Off equally (at doubled speed)
Fatal Error(Need to re-boot):	Solid Red Light (Buzzer emits a long beep)

NOTE:

STO (Safe Torque Off)* status condition includes:

1. Category 0 Stop.
2. Category 1 Stop.
3. Emergency Stop function input LOW signal.

SOS (Safe Operation Stop)* status condition includes:

1. Safeguard function Input LOW signal.
2. Enabling Switch function at OFF Status.
3. Under safety configuration status of either safety-related parameters parameterization, Robot Stick MODE Switch function or Enable/Disable of Robot Stick function.

Refer to *Safety Manual* for details.

*Both names come from IEC 61800-5-2

NOTE:

The different Light Indication of HW3.2 here are:

AUTO Mode: Blue

Recovery Mode: (Not provided in HW3.2)

Maintenance Setting: White

8.2.2 Regular Light Indication

The regular Light Indication alternates between 2 categories of light indication: Operation Mode Light Indication and Auxiliary Light Indication. The blinking ratio of the light indications indicates the various status of the robot. In addition, the display color of Auxiliary Light Indication prioritizes by conditions.

Operation Mode	Running status	Space/Status	Operation Mode Light Indication	Auxiliary Light Indication
MANUAL MODE	Hold to Run or Step Run	Normal	Green (100%)	-
		Error	Green (50%)	Red (50%)
		In Recovery Mode	Green (50%)	Yellow (50%)
		Trigger Maintenance Settings	Green (90%)	Blue (10%)

Hardware Version : 5.02 Document Version : 0

TECHMAN ROBOT INC. 5F., No. 58-2, Huaya 2nd Rd., Guishan Dist., Taoyuan City, 333411, Taiwan

		Trigger Human-Machine Safety Settings	Green (90%)	Purple (10%)
	Project is running	Normal	Green (50%)	Light Off (50%)
		Error	Green (50%)	Red (50%)
		In Recovery Mode	Green (50%)	Yellow (50%)
		Trigger Maintenance	Green (50%)	Blue (50%)
Operation Mode	Running status	Space/Status	Operation Mode Light Indication	Auxiliary Light Indication
		Settings		
		Trigger Human-Machine Safety Settings	Green (50%)	Purple (50%)
	System under SOS status	Normal	Green (10%)	Light Off (90%)
		Error	Green (50%)	Red (50%)
		In Recovery Mode	Green (50%)	Yellow (50%)
		Trigger Maintenance Settings	Green (10%)	Blue (90%)
Trigger Human-Machine Safety Settings		Green (10%)	Purple (90%)	
AUTO MODE	Project is not running	Normal	White (100%)	-
		Error	White (50%)	Red (50%)
		In Recovery Mode	White (50%)	Yellow (50%)
		Trigger Maintenance Settings	White (90%)	Blue (10%)
		Trigger Human-Machine Safety Settings	White (90%)	Purple (10%)
	Project is running	Normal	White (50%)	Light Off (50%)
		Error	White (50%)	Red (50%)
		In Recovery Mode	White (50%)	Yellow (50%)
		Trigger Maintenance Settings	White (50%)	Blue (50%)
		Trigger Human-Machine Safety Settings	White (50%)	Purple (50%)

	Paused in Project or system under SOS status	Normal	White (10%)	Light Off (90%)
		Error	White (50%)	Red (50%)
		In Recovery Mode	White (50%)	Yellow (50%)
		Trigger Maintenance Settings	White (10%)	Blue (90%)
		Trigger Human-Machine Safety Settings	White (10%)	Purple (90%)

8.3 Joint LED Indication

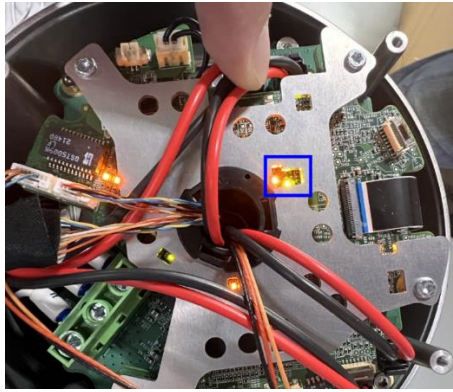

LED Indicator Locations on the Arm Mainboard Assembly

Status		Servo LED (Green)	Error LED (Red)
MCU power on		NA	NA
Error		Error Slow Blink (Refer to the explanation below)	Flashes with Error code (Refer to the explanation below)
FW integrity Fail	Bootstrap	Flashes: Off/On (0.042/0.042 sec)	FW integrity Fail
	Failsafe	Flashes: Off/On (0.168/0.168 sec)	Always On
Without FW		Never On	Never On
Servo on		Fast Blink	Never On
Servo off		Slow Blink	Never On

9. Other Software for support functions

9.1 Debug port

9.1.1 Tool list

Item	Description
Laptop	Used for installing Tera term and CP2102 driver
USB cable	Used for connecting control box and laptop. Type C to Type A is recommended *Need data transfer function
CP2102 *Software	To ensure that the laptop correctly detects the debug port Recommended download link: https://www.silabs.com/developers/usb-to-uart-bridge-vcp-drivers?tab=downloads
Tera term *Software	Used for establishing the connection and displaying the information Recommended download link: https://ttssh2.osdn.jp/index.html.en

9.1.2 Power up the control box and connect it to the laptop by using a USB cable.

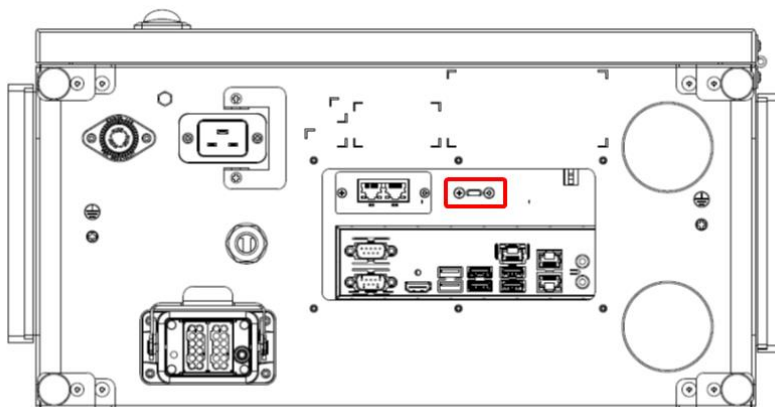

9.1.3 Activate Tera Term and then close the pop-up window by selecting "Cancel" or "Close"

*The COM port number will need to be set at 7.1.5

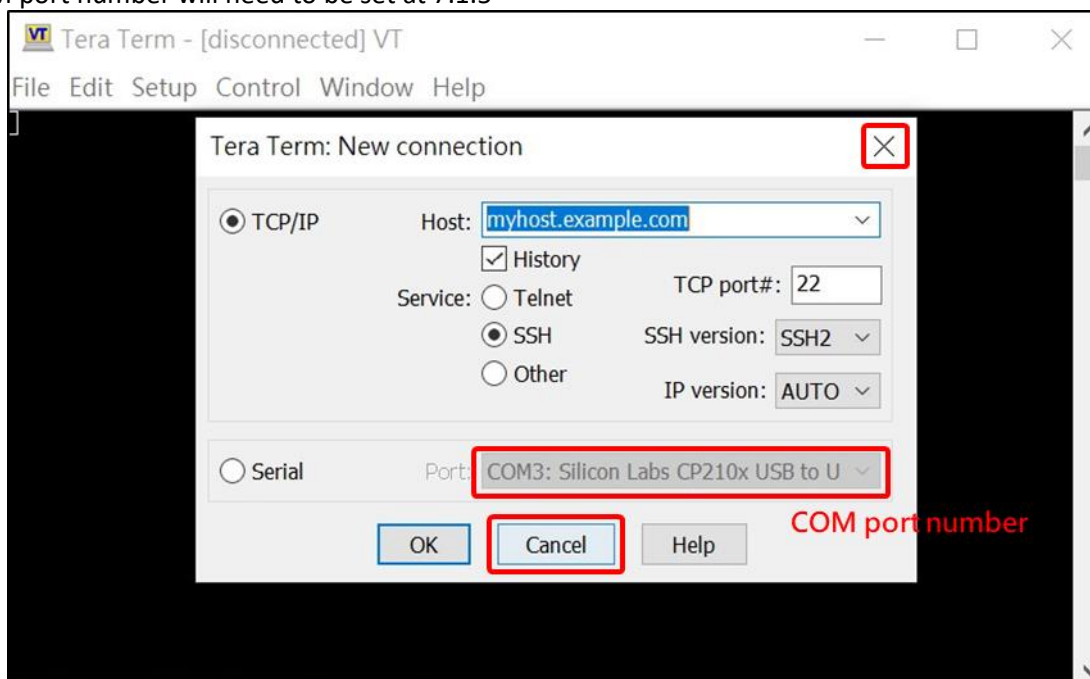

9.1.4 Choose "Setup" and then select "Serial Port"

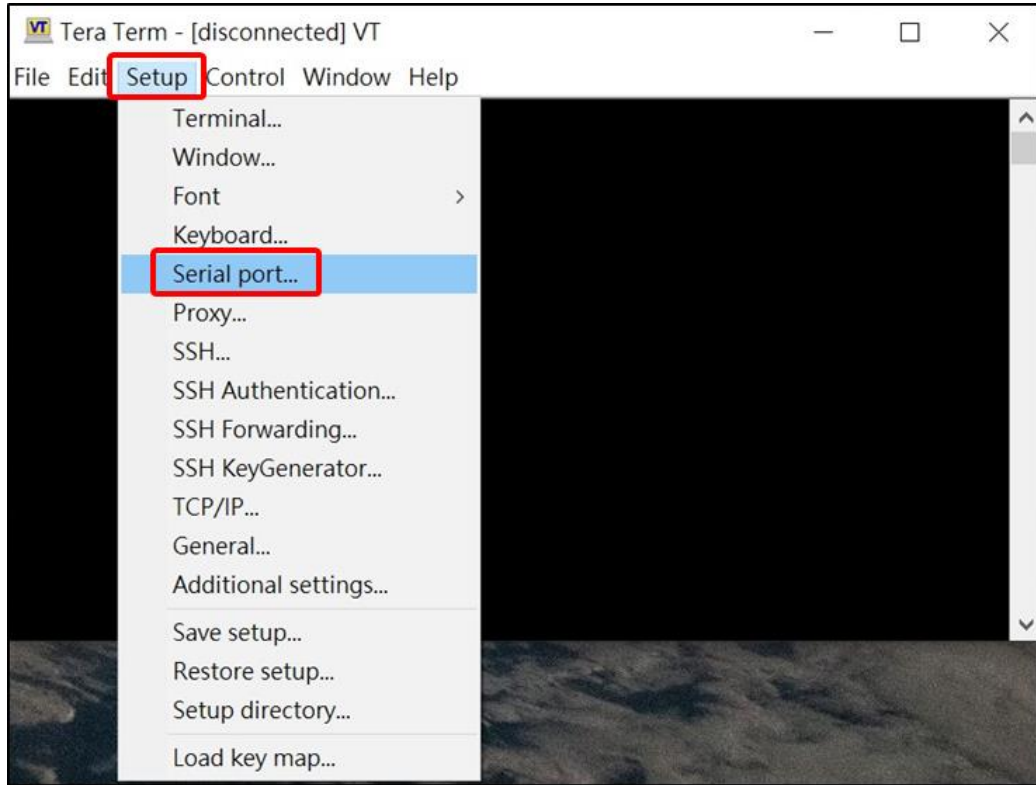

9.1.5 Choose the port as indicated in step 2; set the speed to 921600, and then click on "New open"

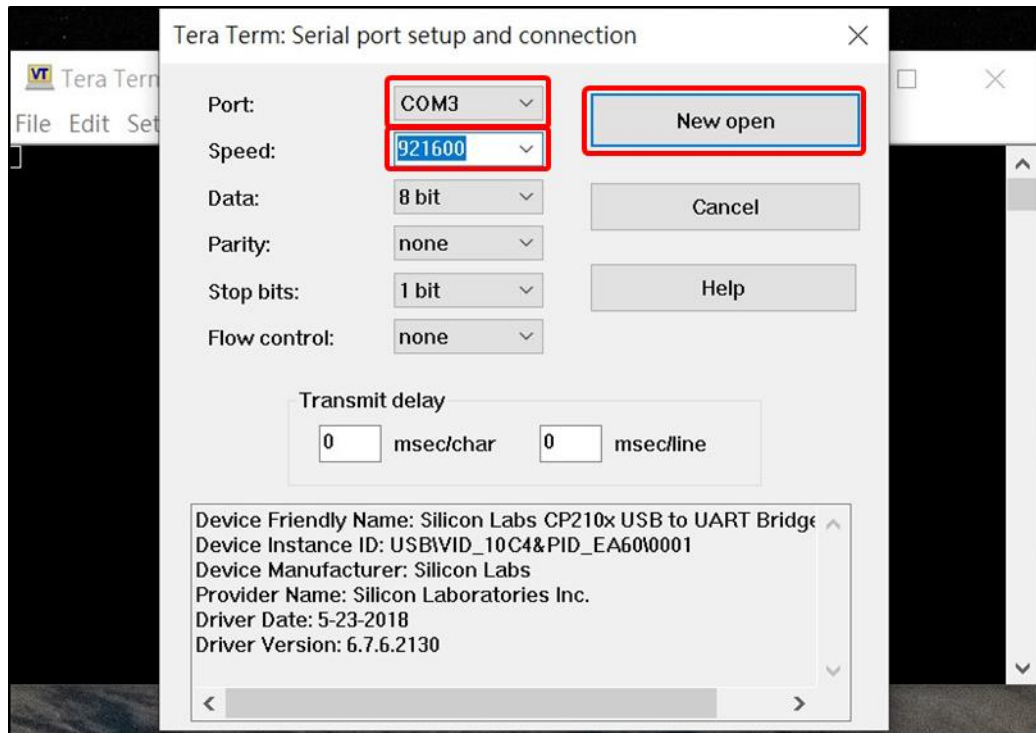

9.1.6 Following screen indicates a successful connection.

```

COM3 - Tera Term VT
File Edit Setup Control Window Help
=== Techman Robot status console ===
Model = IMB (0x02) AC 220V (max 80.000000A)
H/W = 20230301-G5.Hx.0 PID = 0x02081E20
F/W = 20230717-040.0.0 Date = Jul 17 2023
ESC Status :----P0-P1-P2-P3---- ESW
          IF 00 00 00 00 | PU      Init
          RxE 00 00 00 00 | 00     Pre-OP
          FRxE 00 00 00 00 | PDI   Safe-OP
          LL 00 00 00 00 | 00     OP
POWER key : OFF ON
Peripheral Comm. Status : ESC ADC DAC1 DAC2 EEPROM
FAN state : OFF ON
48V Power Status : +exPSU PSU on Limited Full
PSU voltage = 48.252895 V(1st), 47.871837 V(2nd)
STO voltage = 0.084678 V Patriot not ready
m48 voltage = 0.155244 V
m48 current = -0.166500 A
s48 voltage = 48.000000 V
s48 current = 0.032351 A
24V Power Status : Internal External
IPC voltage = 24.232601 V
i24 current = 0.030689 A
s24 current = 1.647949 A
Temperature = 34.413806 C
Configurable Digital I/O : Normal Configured Mask = 00000000
Digital Output[15..0] = 0000 (....) enabled
Digital Input[15..0] = 0000 (....) Input filter : disabled
Analog Output[0] = 0000 ( 0.000000 V) enabled
Analog Output[1] = 0000 ( 0.000000 V) enabled
Analog Input[0] = 7FF8 (-0.002656 V)
Analog Input[1] = 8000 (-0.000156 V)
Analog Input[2] = 8001 (-0.000781 V)
Analog Input[3] = 8000 ( 0.000156 V)
--- INFORMATION list ---
--- CAUTION list ---
--- WARNING list ---
=== End ===

```

9.2 System recovery

9.2.1 This function is used to restore Disk C to the factory settings, while Disk D (e.g., projects, HMI configurations, etc.) will remain unchanged.

9.2.1 Press the Del key during startup to enter the BIOS.

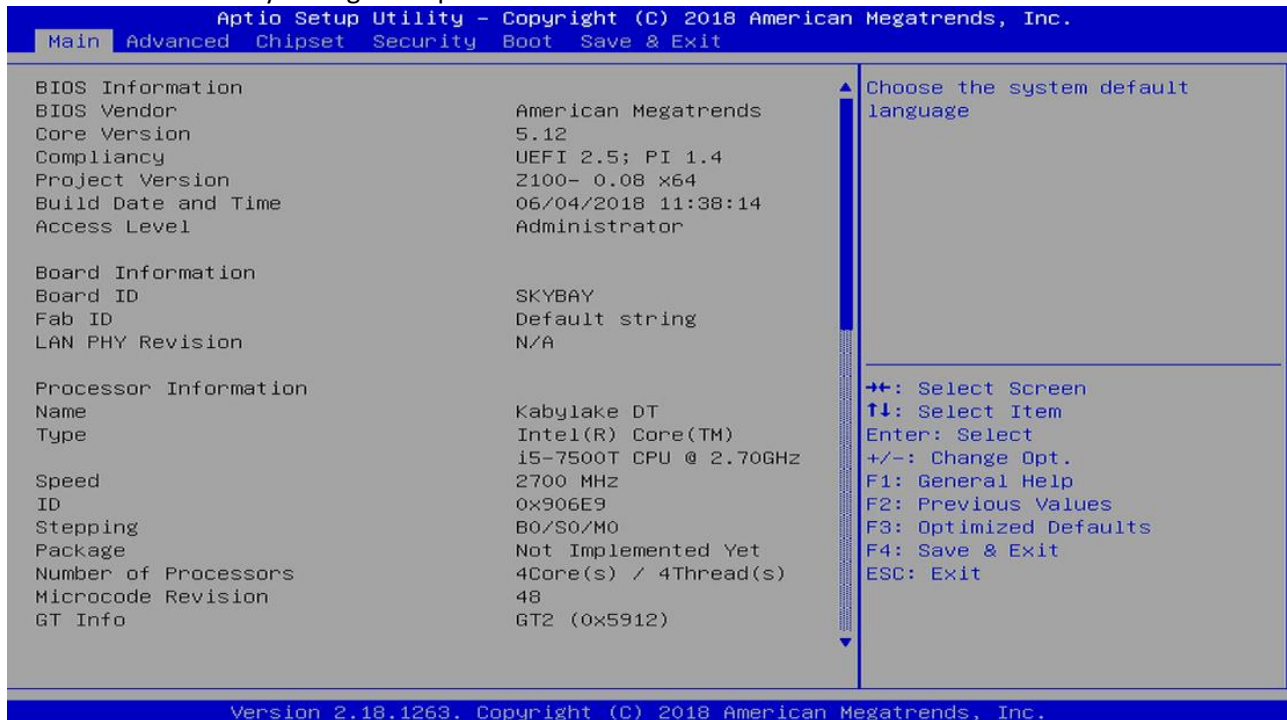

9.2.1 Open the outer casing of the control box, and press and hold the black button on the SSD for more than 5 seconds. The red light will start flashing

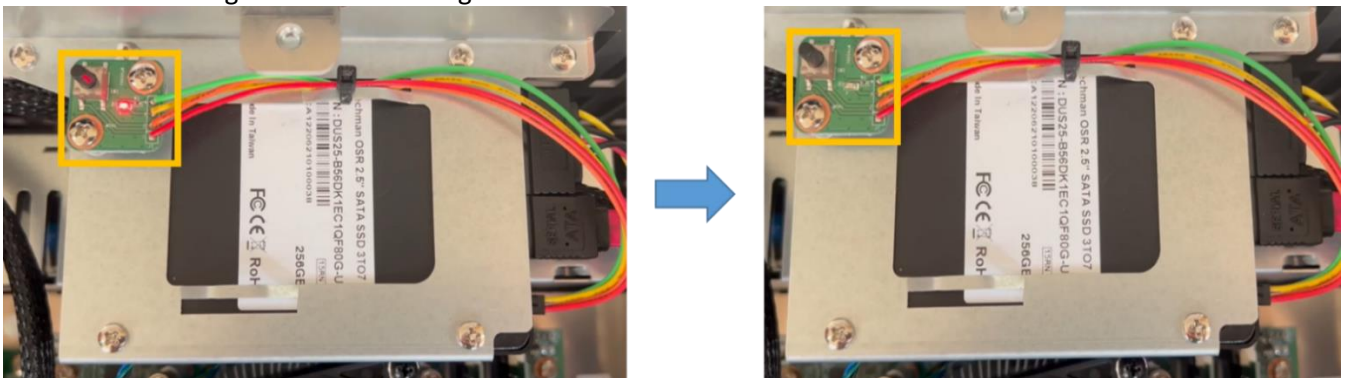

9.2.1 After waiting for 15 minutes, the system will complete the restoration, and the red light will become steady. Once the red light is steady, you can exit the BIOS, restart the system, and Disk C will be restored to its factory state.



9.3 Arm Exchange: This function is designed for situations where either the arm or the control box experiences abnormalities. In cases of urgency, where the customer needs to quickly resume production on the assembly line, arm exchange can be performed to avoid production line downtime. As illustrated below, if Arm A is damaged, this feature facilitates the exchange of Arm A with the available Arm B in stock, enabling the production line to continue operations.

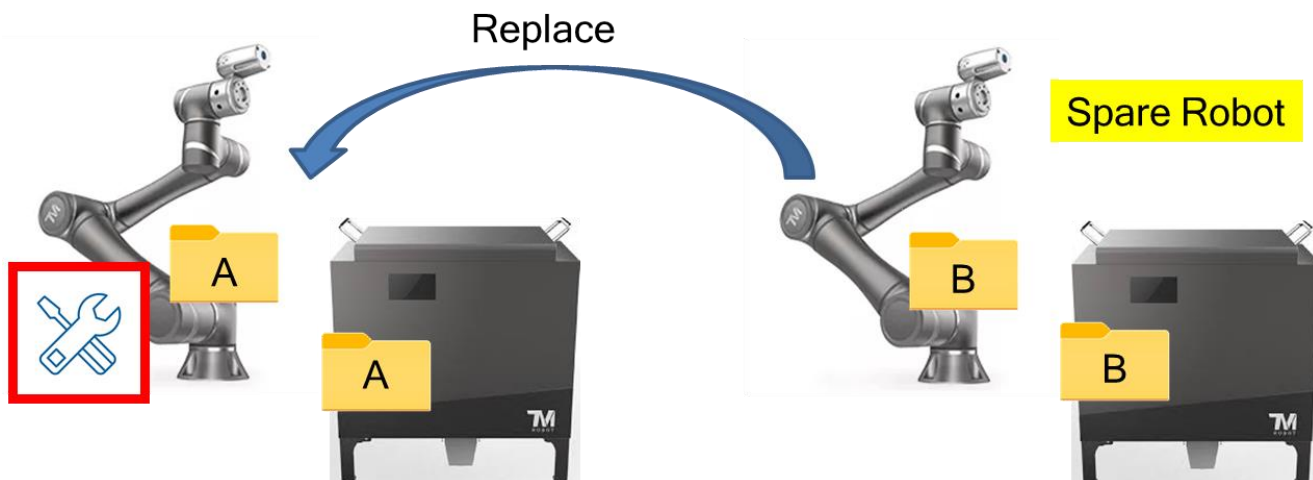

9.3.1 Remove the malfunctioning arm and directly connect the spare arm to the original control box. The calibration data stored in the arm's IO board will overwrite the data in the original control box, so it's crucial to back up the files in the original control box. The software will check whether the data between the arm and control box matches.

The following scenarios will explain the handling when the arm firmware (FW) does not match the control box HMI.

9.3.2 If the arm FW is version 2.12 but the spare control box's HMI version is 2.14, the user can choose to restore the control box's HMI image to version 2.12 or upgrade the arm FW to version 2.14.

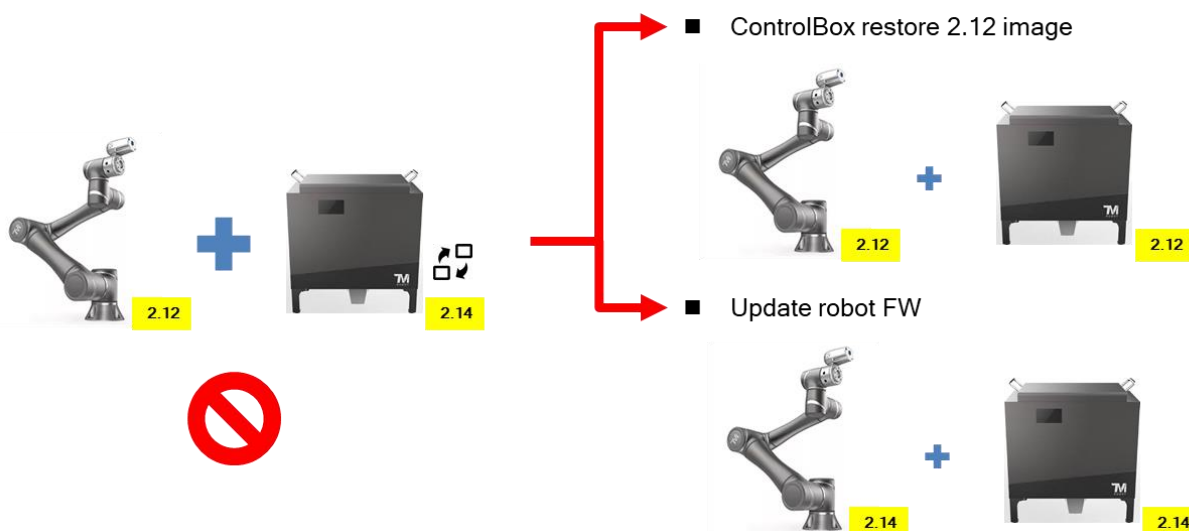

9.3.1 Joint type When the arm FW is version 2.14, but the spare control box's HMI version is 2.12, the user can only upgrade the control box's HMI to match the FW. The main reason is that older versions of software or firmware may not recognize the new Joint type.

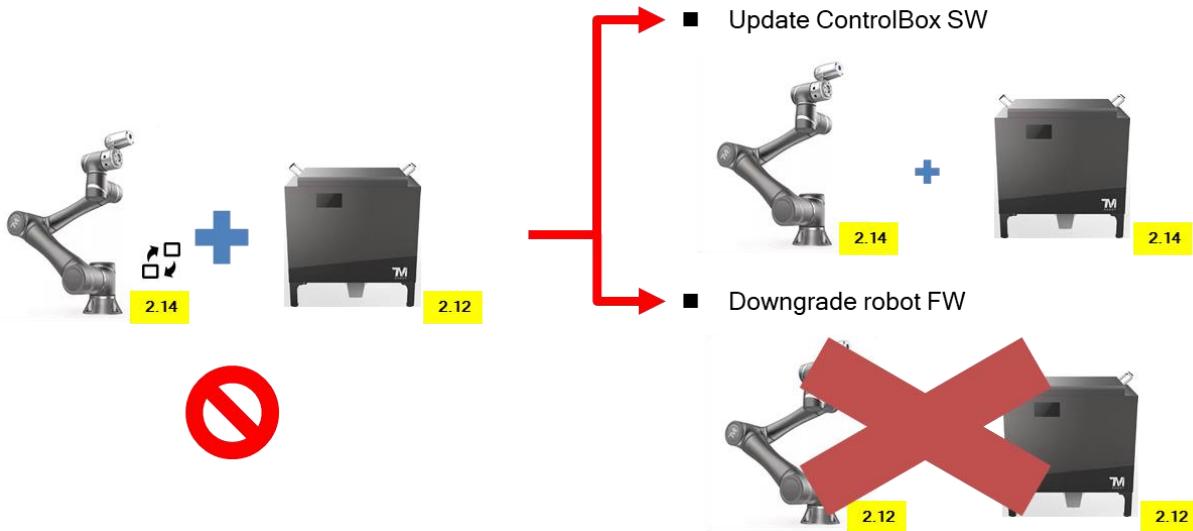

9.3.2 Not every arm and control box can support interchangeability. Exchange can only occur when Arm Model and Control Box Model are mutually compatible. TM25S can only exchange the arm and control box with same model.

9.3.3 The flowchart below showing the process that the system will follow in the background after swapping the arm with the control box. If there are no errors or anomalies during the process, it is considered a successful interchange. For troubleshooting in case of abnormal situations, please refer to the Appendix.

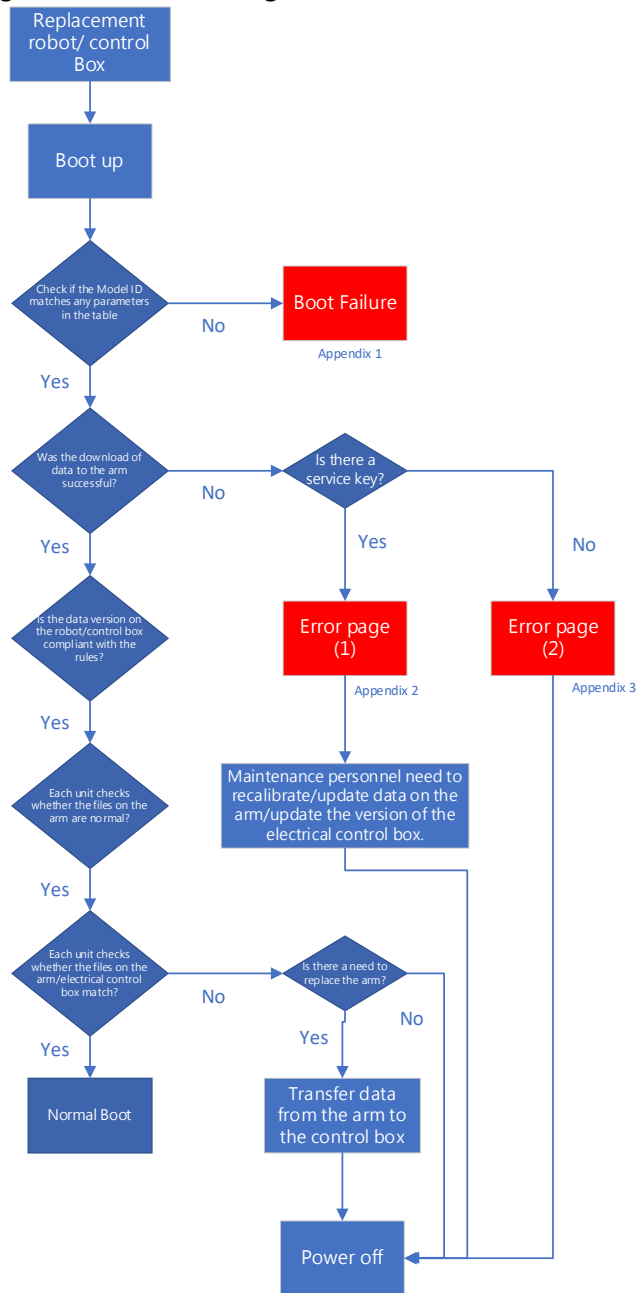

Appendix 1

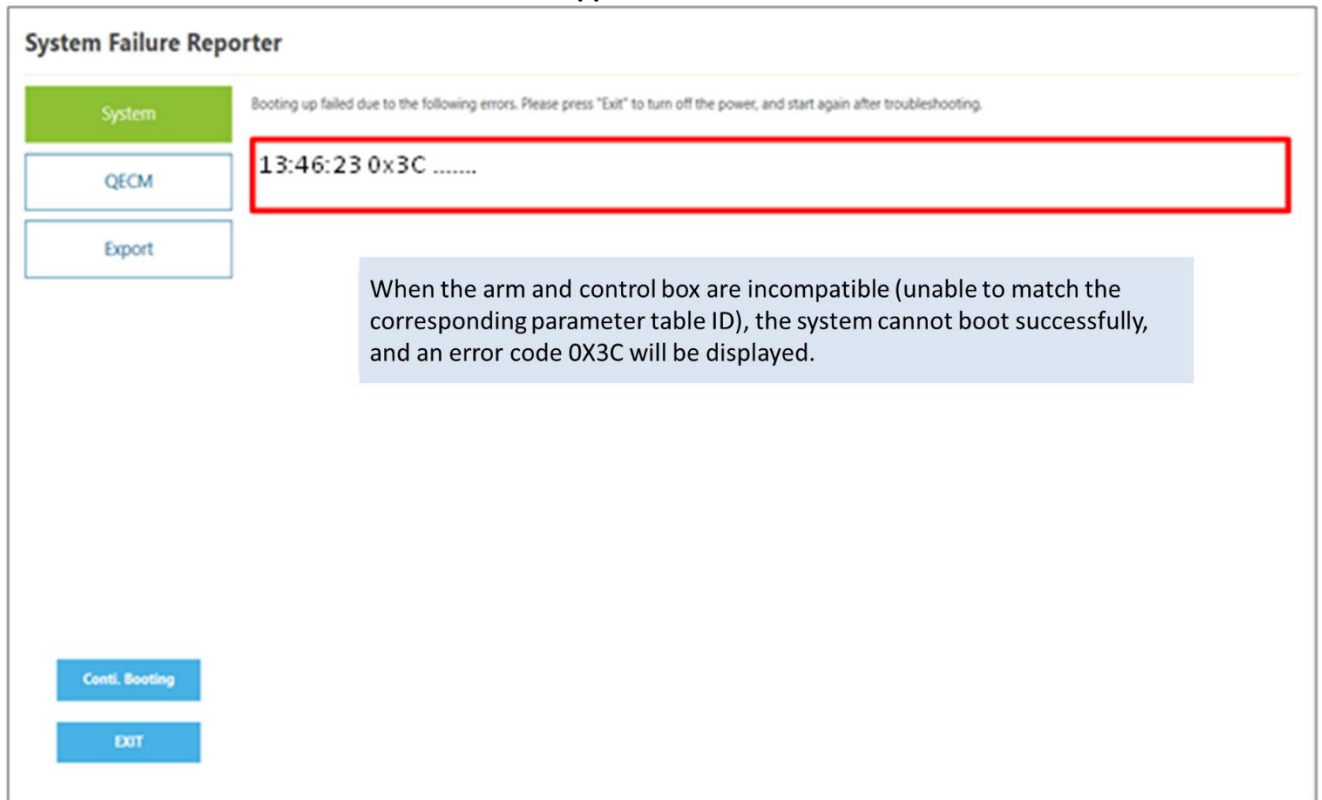

- This issue indicates that the arm and control box combination may not support interchangeability. Please double-check the compatibility list to ensure that the combination is valid. If it is a valid combination and you still encounter this problem, it is recommended to contact the headquarters' engineers for further assistance.

Appendix 2

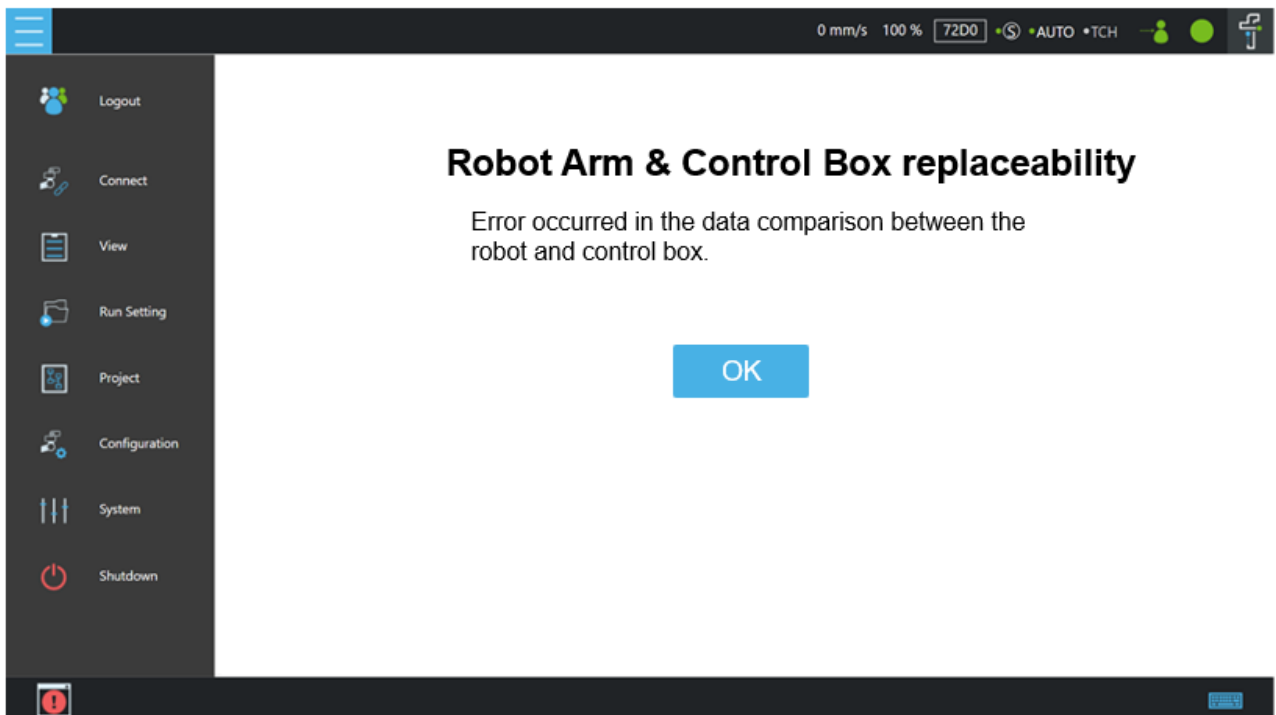

- This error indicates a data comparison issue, and it may trigger a special page with log entries such as 0x00045240 (download failed or data error) or 0xF0000180 (version comparison failed).
- The maintenance personnel need to recalibrate/update arm-end data/update control box version.

Hardware Version : 5.02 Document Version : 0

TECHMAN ROBOT INC. 5F., No. 58-2, Huaya 2nd Rd., Guishan Dist., Taoyuan City, 333411, Taiwan

Appendix 3

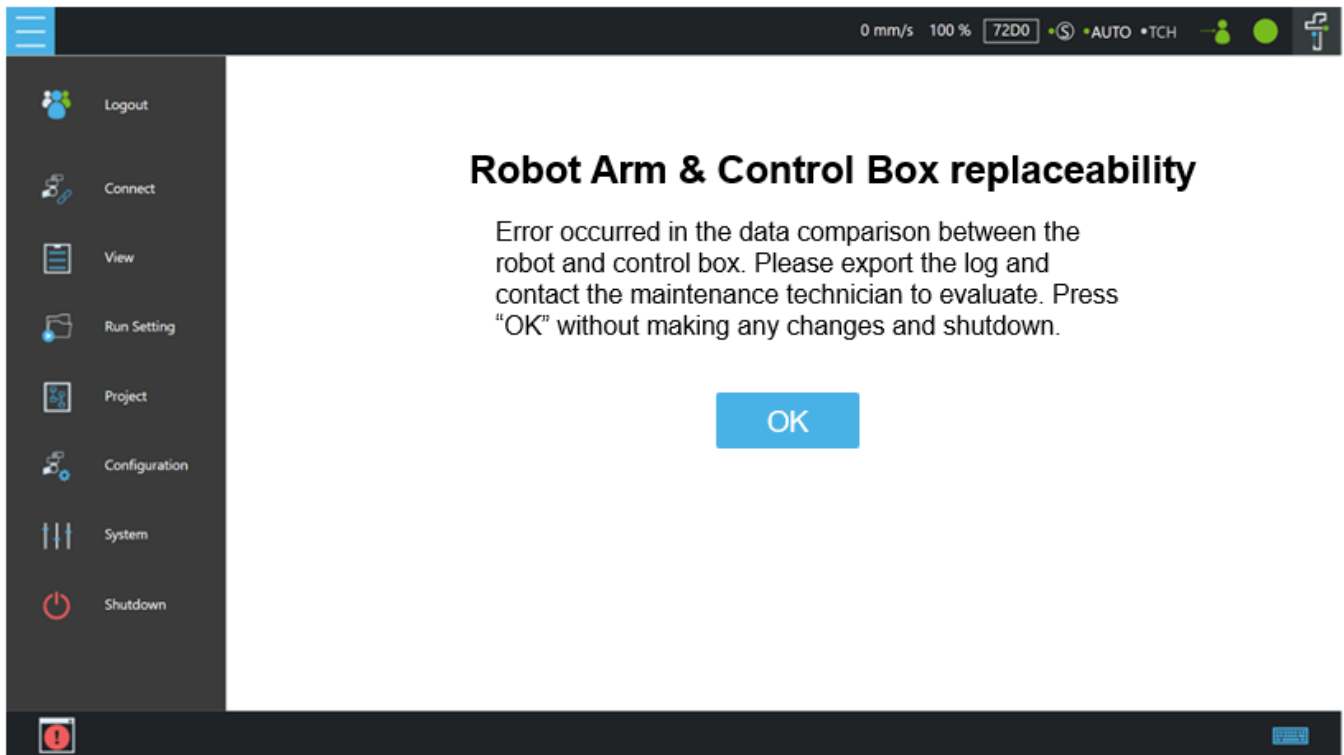

- The error message "Data comparison error prompts a special page and logs 0x00045240 (download failed or data error) or 0xF0000180 (version comparison failed). Please export the logs and contact the headquarters maintenance personnel for assistance

Appendix 4

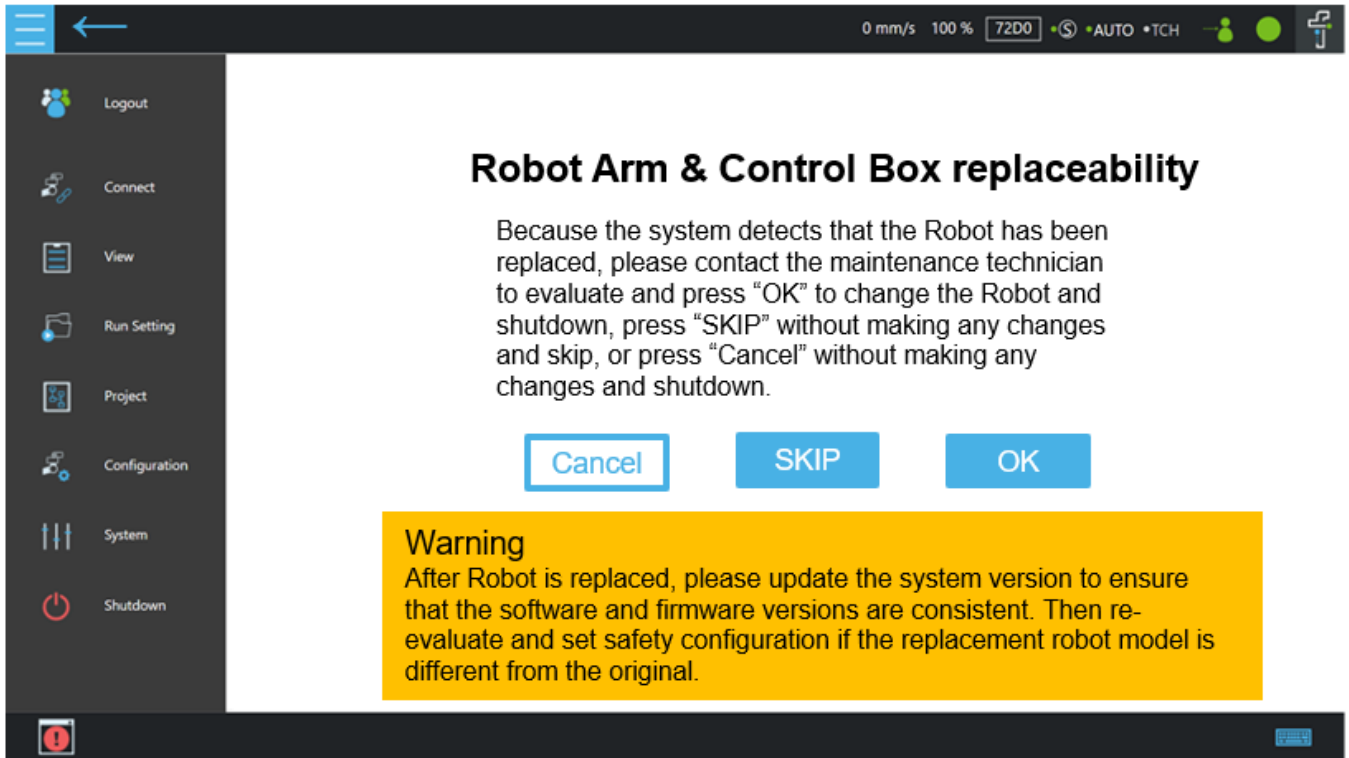

If all the above criteria are met, but the data on the arm side differs from the data on the control box side, switch to this special page after turning on the machine.

Cancel : Do not make any changes. Click to initiate the shutdown procedure.

SKIP : No changes needed. Click to exit this special page. If there is no service key, the button will be greyed out and cannot be clicked.

OK : Overwrite the data of the arm side to the control box side, and switch off the machine, if there is no Service key, the button will be greyed out and cannot be clicked.

Note: The visual connection camera check takes approximately 60 seconds. During Normal power on, the page may jump to this special page after a period of time. The check will first go to the Normal condition, and then jump to this special page when any unit is checked to a different condition.

Please click 'OK' and enter the Safety Password to confirm the arm change. This password is the same as the Safety Configuration Tool Password.

After replacing the arm, update the system version to ensure the firmware version remains the same. If the arm model has been changed, conduct a new safety assessment and modify the safety function settings

10. Calibration guide

Reference the order of images in the following sections for calibration.

10.1 Before Calibration



Contents

1. Tools and space
2. Settings for calibration
3. Dynamic calibration and Hand-guide calibration
4. Camera calibration
5. Kinematic calibration
6. Hand-eye calibration and Verification
7. Barcode setting
8. Save the calibration data

Notes

1. To avoid collisions, remove the gripper, cables, and external devices before performing calibration.
 2. X-series robots only need to undergo Dynamic and Hand-guide calibration.
 3. Robots that have experienced collision or have been tilted may not pass calibration. They should be repaired, and ensure that there are no tilted joints when in the home pose.
- ✘ **Whenever doing which Kind of Calibration. Calibration data needs to be saved after the calibration is completed to avoid unexpected errors.**

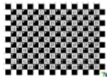
10.2 Tool list and Space requirement

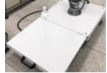
1	Maintenance dongle	
2	Small dice board	
3	Big dice board	
4	Landmark	
5	Calibration platform	

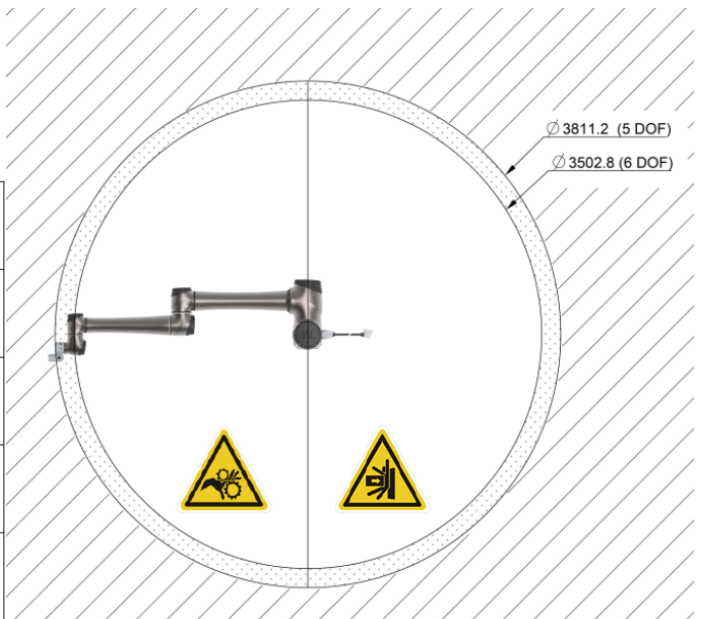

10.3 Setting

*Please restore the following settings after the calibration process is completed.
*Insert the maintenance dongle before perform following steps and calibration.

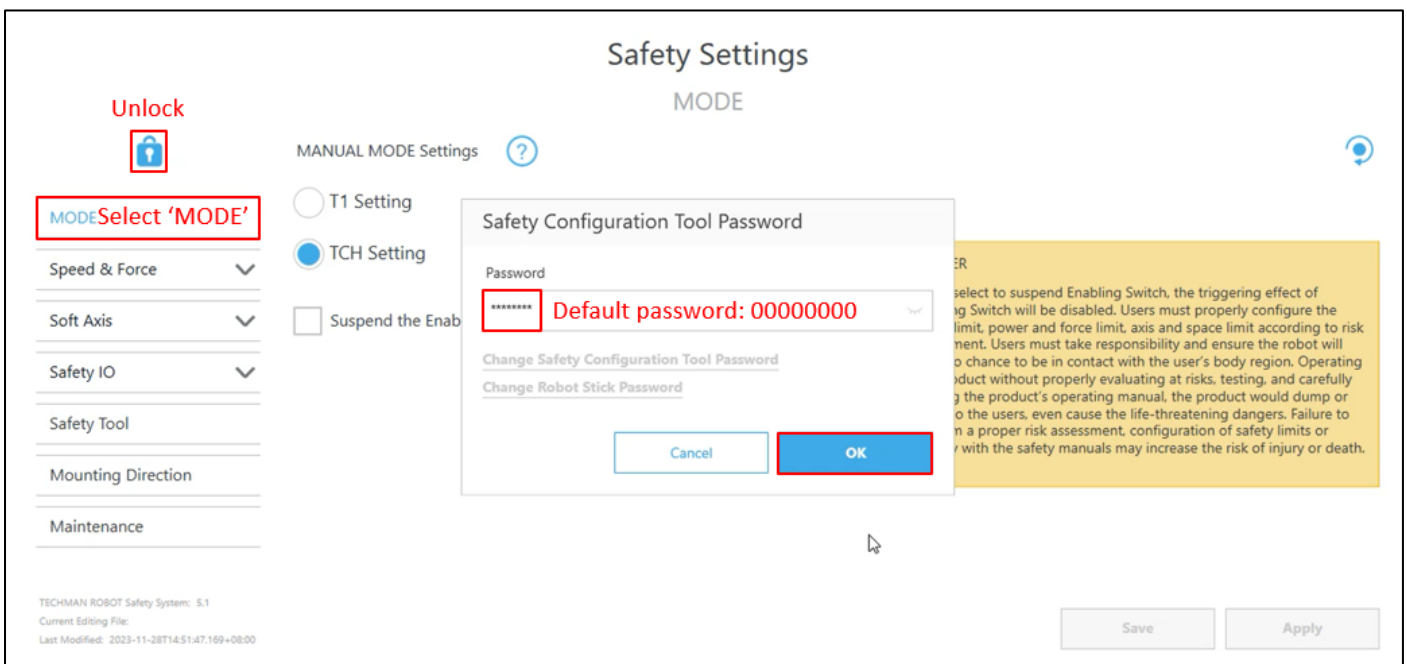
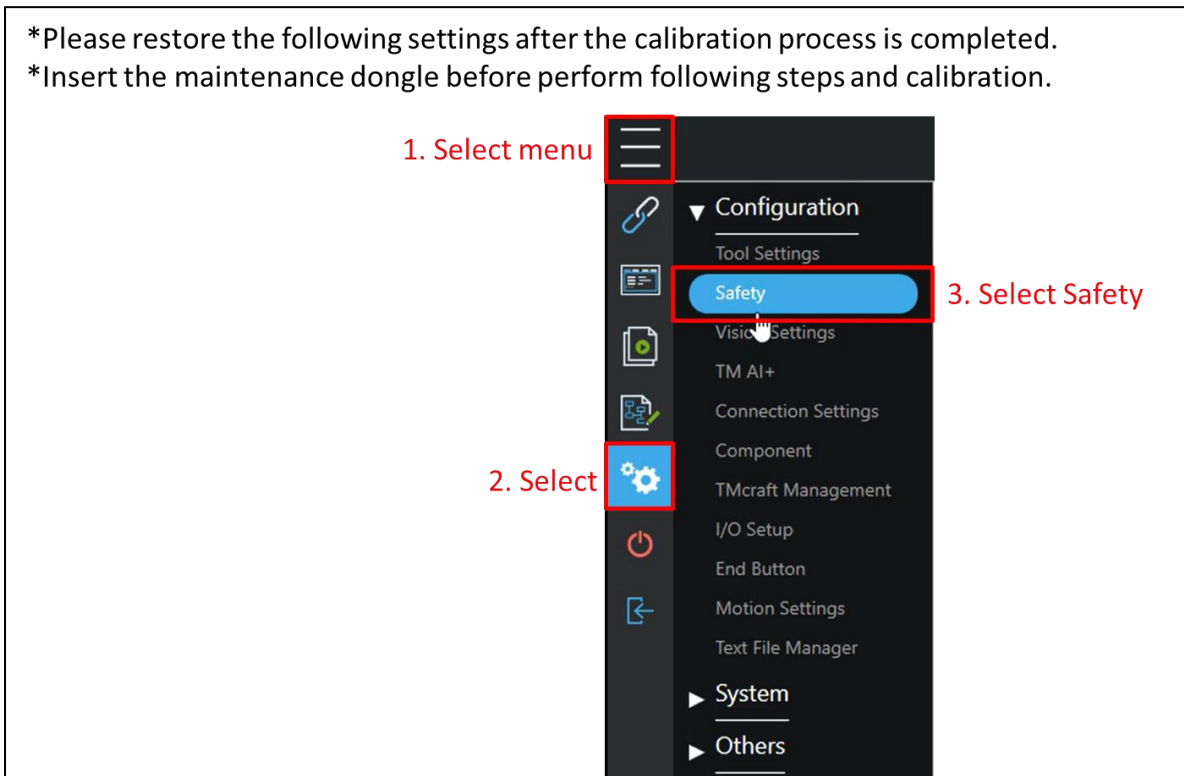

Safety Settings

MODE



MANUAL MODE Settings ?



MODE

T1 Setting

Speed & Force

TCH Setting

Soft Axis

Suspend the Enabling Switch

Safety IO

Safety Tool

Mounting Direction

Maintenance

DANGER

When select to suspend Enabling Switch, the triggering effect of Enabling Switch will be disabled. Users must properly configure the speed limit, power and force limit, axis and space limit according to risk assessment. Users must take responsibility and ensure the robot will have no chance to be in contact with the user's body region. Operating the product without properly evaluating at risks, testing, and carefully reading the product's operating manual, the product would dump or pinch to the users, even cause the life-threatening dangers. Failure to perform a proper risk assessment, configuration of safety limits or comply with the safety manuals may increase the risk of injury or death.

TECHMAN ROBOT Safety System: 5.1
Current Editing File:
Last Modified: 2023-11-28T14:51:47.169+08:00

Save

Apply

Apply Safety Configuration

Last modified time: 2023-12-26T14:06:47.924+08:00
Safety System version: 5.1
Safety Checksum: D22A
Robot Name: CC2324034
Robot model: TM55

Mode Settings

MANUAL MODE Settings:TCH Setting
Suspend the Enabling Switch True

Speed & Force Setting

General Setting
Hand Guide TCP Speed
T1 Hand Guide TCP Speed Limit:250 mm/sec
TCH Hand Guide TCP Speed Limit:450 mm/sec
End-Point Reduced Speed
End-Point Reduced Speed Limit:250 mm/sec
Force & Torque Limit function
Robot in the fenceless workspace
Human-Machine Safety

I have confirmed all the safety parameters according to my settings.

Triggering effect of Enabling Switch will be disabled. Users must properly configure the speed limit according to risk assessment. Users must take responsibility and ensure the robot will have no chance to be in contact with the user's body region. Operating the product without properly evaluating at risks, testing, and carefully reading the product's operating manual, the product would dump or pinch to the users, even cause the life-threatening dangers. Failure to perform a proper risk assessment, configuration of safety limits or comply with the safety manuals may increase the risk of injury or death.

TECHMAN ROBOT Safety System: 5.1
Current Editing File:
Last Modified: 2023-11-28T14:51:47

Cancel

OK

Apply

Safety Settings

MODE

MODE

Speed & Force

Soft Axis

Safety IO

Safety Tool

Mounting Direction

Maintenance

MANUAL MODE Settings

T1 Setting

TCH Setting

Suspend the Enabli

Save

Apply

Save Safety Report

Device: 0 \USB\TMROBOT

Space:
■ 37,883 MB ■ 80,486 MB

...select to suspend Enabling Switch, the triggering effect of ...ing Switch will be disabled. Users must properly configure the ...d limit, power and force limit, axis and space limit according to risk ...ment. Users must take responsibility and ensure the robot will ...no chance to be in contact with the user's body region. Operating ...product without properly evaluating at risks, testing, and carefully ...ng the product's operating manual, the product would dump or ...to the users, even cause the life-threatening dangers. Failure to ...rm a proper risk assessment, configuration of safety limits or ...ly with the safety manuals may increase the risk of injury or death.

TECHMAN ROBOT Safety System: 5.1
Current Editing File:
Last Modified: 2023-12-26T14:06:47.924+08:00

Safety Settings

Maintenance

Unlock

MODE

Speed & Force

Soft Axis

Safety IO

Safety Tool

Mounting Direction

Maintenance

Select 'Maintenance'

Maintenance Settings

Suspend the safety f

- Joint Speed Limit, S
- Joint Torque Limit, l
- Joint Position Limit,
- The effect of Hum

Save

Apply

Safety Configuration Tool Password

Password: ***** Default password: 00000000

Change Safety Configuration Tool Password

Change Robot Stick Password

...end safety functions, the speed limit, power and force limit, ...the triggering effect of Human-Machine Safety Settings will ...er must take responsibility and ensure the robot will have no ...tact with the user's body region. User must un-select the ...functions listed below" to set all the suspended safety ...ctioning after finishing maintenance procedure.

TECHMAN ROBOT Safety System: 5.1
Current Editing File:
Last Modified: 2023-12-26T14:06:47.924+08:00

Safety Settings

Maintenance



Maintenance Settings

MODE

Speed & Force

Soft Axis

Safety IO

Safety Tool

Mounting Direction

Maintenance

Suspend the safety functions listed below:

- Joint Speed Limit, Speed Limit, End-point Reduced Speed Limit
- Joint Torque Limit, Force Limit
- Joint Position Limit, Cartesian Limit A, Cartesian Limit B
- The effect of Human-Machine Safety Settings

DANGER

When select to suspend safety functions, the speed limit, power and force limit, axis and space limit, the triggering effect of Human-Machine Safety Settings will be disabled. The user must take responsibility and ensure the robot will have no chance to be in contact with the user's body region. User must un-select the "Suspend the safety functions listed below" to set all the suspended safety functions back to functioning after finishing maintenance procedure.

TECHMAN ROBOT Safety System: 5.1
Current Editing File:
Last Modified: 2023-12-26T14:06:47.924+08:00

Save

Apply

Apply Safety Configuration

Last modified time: 2023-12-26T14:07:33.707+08:00
Safety System version: 5.1
Safety Checksum: 177B
Robot Name: CC2324034
Robot model: TM55

Mode Settings

MANUAL MODE Settings:TCH Setting
Suspend the Enabling Switch True

Speed & Force Setting

General Setting
Hand Guide TCP Speed
T1 Hand Guide TCP Speed Limit:250 mm/sec
TCH Hand Guide TCP Speed Limit:450 mm/sec
End-Point Reduced Speed
End-Point Reduced Speed Limit:250 mm/sec
Force & Torque Limit function
Robot in the fenceless workspace
Human-Machine Safety

I have confirmed all the safety parameters according to my settings.

When select to suspend safety functions, the speed limit, power and force limit, axis and space limit, the triggering effect of Human-Machine Safety Settings will be disabled. The user must take responsibility and ensure the robot will have no chance to be in contact with the user's body region. User must un-select the "Suspend the safety functions listed below" to set all the suspended safety functions back to functioning after finishing maintenance procedure.

TECHMAN ROBOT Safety System: 5.1
Current Editing File:
Last Modified: 2023-12-26T14:06:47.

Cancel

OK

Apply

10.4 Dynamic calibration & Hand-guide calibration

To access the page of Hand Guide Calibration and Dynamic Calibration, the robot should be set as MANUAL MODE first.

The method to switch from AUTO MODE to MANUAL MODE is as follows:

Step 1 Press and hold the **M/A** button on Robot Stick.

Step 2 Type in a valid password. (Default password: + - + -)

Step 3 Press the **M/A** button to send out the password, and the system will wait 30 seconds for the confirmation.

Step 4 Press the **M/A** button to confirm or the STOP button to cancel.



▲ Robot stick

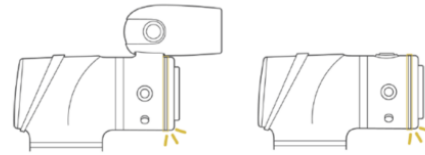

▲ AUTO MODE: The Indication Light Ring of The End Module with White Light

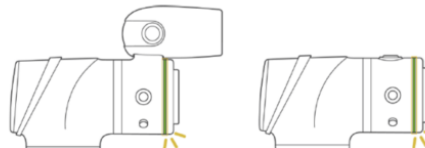

▲ MANUAL MODE: The Indication Light Ring of The End Module in Green

1. Select the @TMField_DynamicCalibration
2. Switch the robot into auto mode and run the project.

Current	Name	Speed	Build date	Last updated date	Last execution date
<input checked="" type="radio"/>	@TMField_DynamicCalibration	100%			
<input type="radio"/>	@TMField_HandGuideCalibration	100%			

Dynamic calibration is running

Robot ID=TMA-130ACA
Robot Arm Length=1300
ControlBoxSN =
ArmSN=
SafetyResult =
Inertia=(0,0,0,0,0,0,0)
Viscosity=(0,0,0,0,0,0,0)
CoulombFriction=(0,0,0,0,0,0,0)
total_time=102992.0848

system_temperature=28.86768
drv_temperature=(31.800001,30.800001,38.600002,35.600002,38.38,0,0)
489Info=(47.869,1.2207031)
24VInfo=(24,1,0)
IO24VInfo=(0,027832942,0)
NetPacketInfo=(90867524,1387,1000,0038452148438,0,0)

Dynamic calibration completed

Robot ID=TMA-130ACA
Robot Arm Length=1300
ControlBoxSN =
ArmSN=
SafetyResult =159.8322, 194.9395, 58.4815, 7.2347, 7.0210, 7.4523, 0.0000, 0.0000
50.0000, 50.0000, 50.0000, 5.0000, 5.0000, 5.0000, 0.0000, 0.0000
485.9409, 820.1389, 286.2932, 48.8171, 73.6903, 61.7600, 0.0000, 0.0000
100.0000, 100.0000, 100.0000, 50.0000, 50.0000, 50.0000, 0.0000, 0.0000
14387.9189, 17067.2617, 9262.1924, 2318.8035, 2753.6929, 2715.4309, 0.0000, 0.0000
3000.0000, 3000.0000, 3000.0000, 1000.0000, 1000.0000, 1000.0000, 0.0000, 0.0000

Inertia=(159.8322,194.9395,58.4815,7.2347,7.021,7.4523,0,0)
Viscosity=(485.9409,820.1289,286.2932,48.8171,73.6903,61.76,0,0)
CoulombFriction=(14387.919,17067.262,9262.192,2318.8035,2753.6929,2715.431,0,0)
total_time=117992.9389

system_temperature=28.86768
drv_temperature=(31.7,30.800001,38.600002,35.600002,37.8,38,0,0)

1. Select the @TMField_HandGuideCalibration
2. Switch the robot into auto mode and run the project.

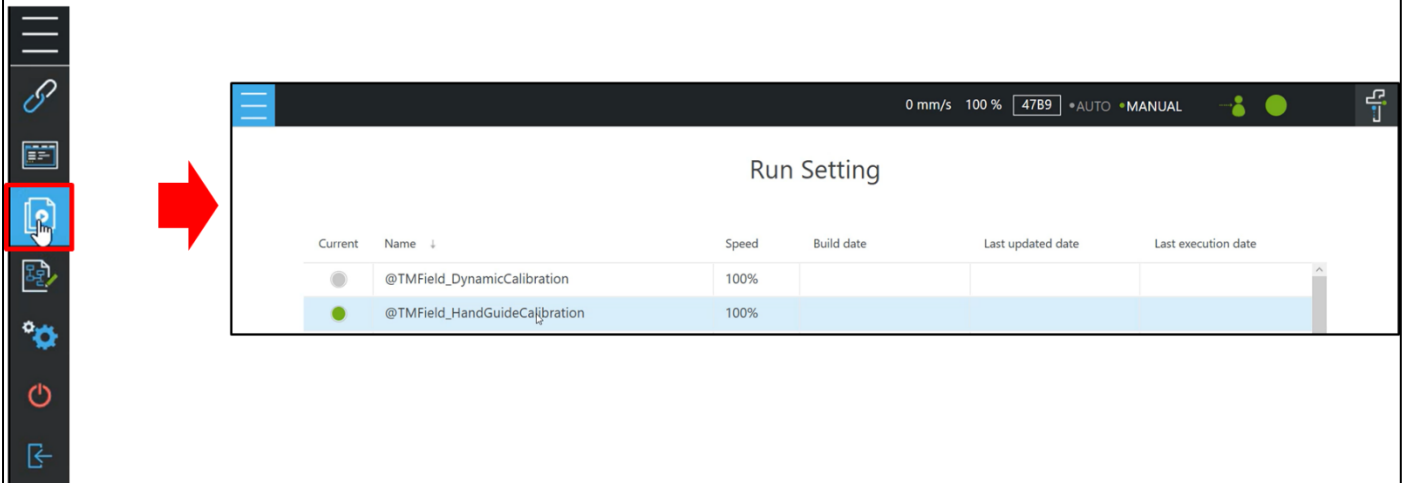

Hand-guide calibration is running

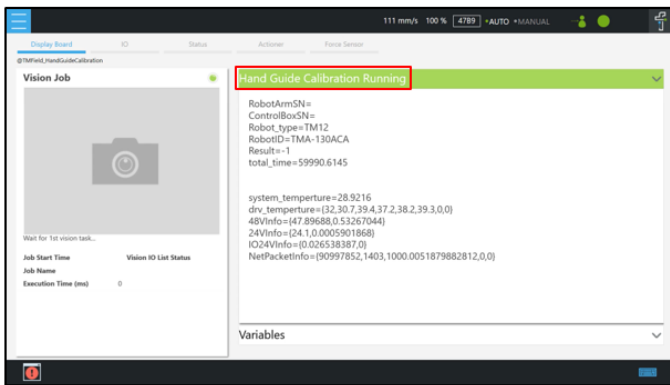

Hand-guide calibration completed

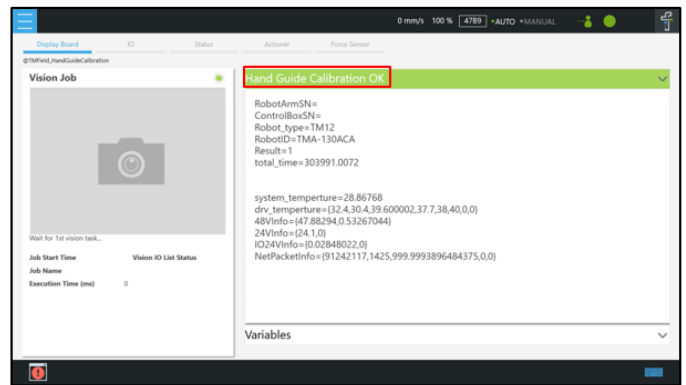

10.5 Camera Calibration

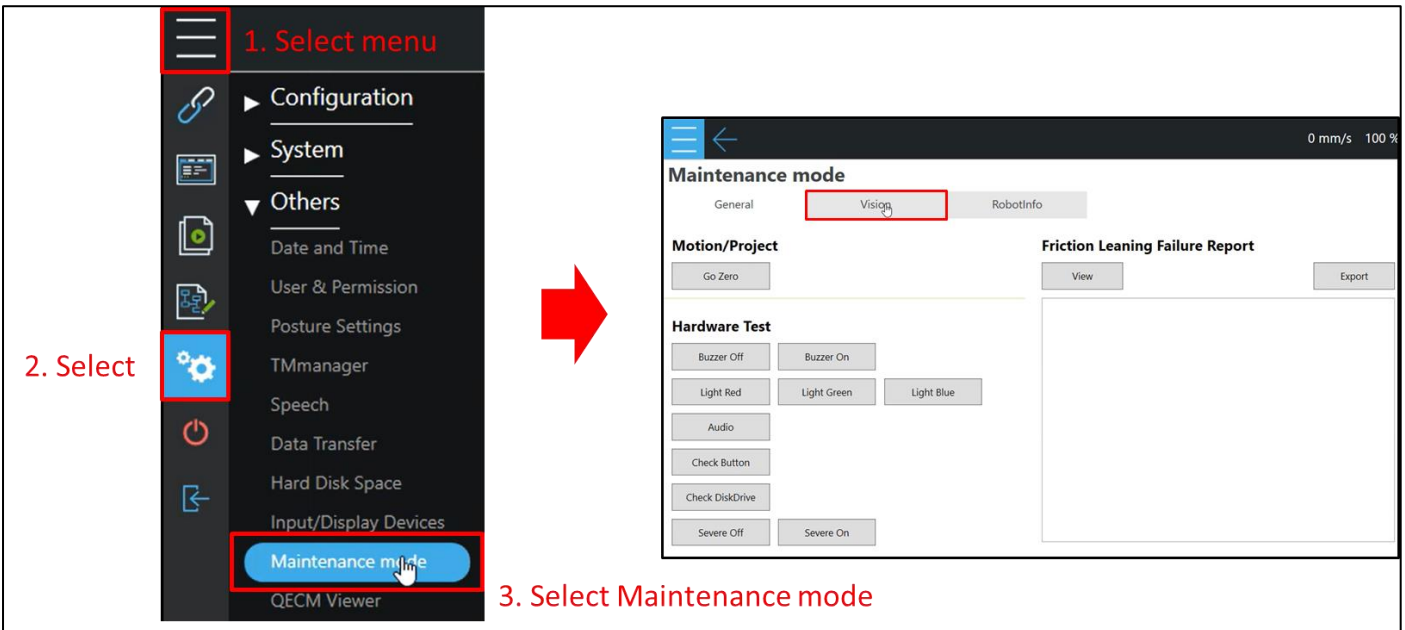

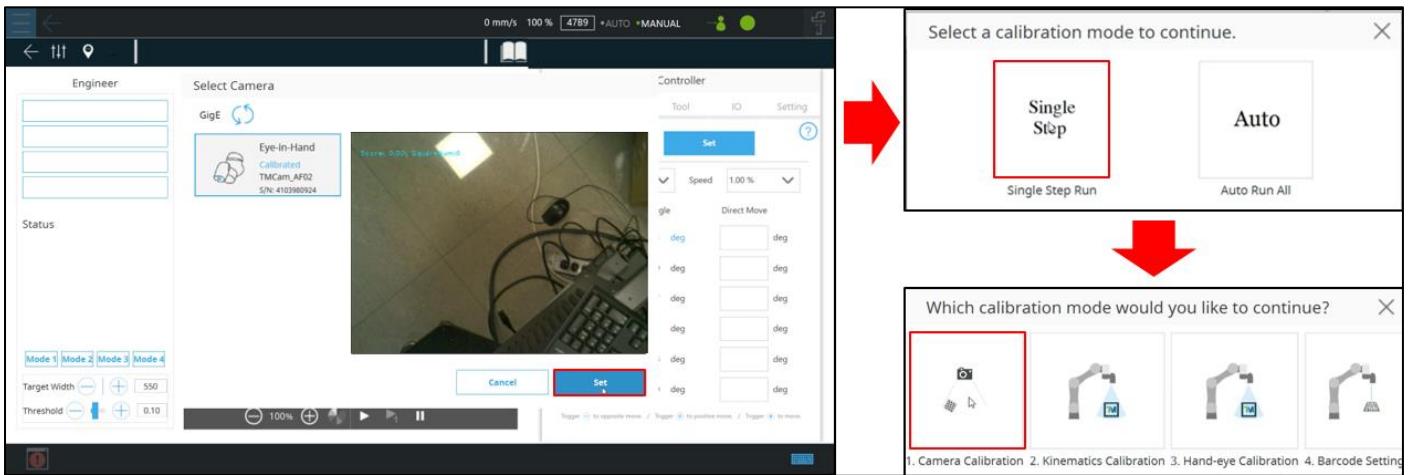

1. Use ① to move the robot to the designated position, then place the **small dice board** and make sure the camera can see the entire dice board as shown in ②
2. Use ③ to adjust the parameters (it is recommended to turn on the flash before adjusting all parameters to Auto once)
3. After setting up, click ④ 1-cm Plate Calibration to start the calibration

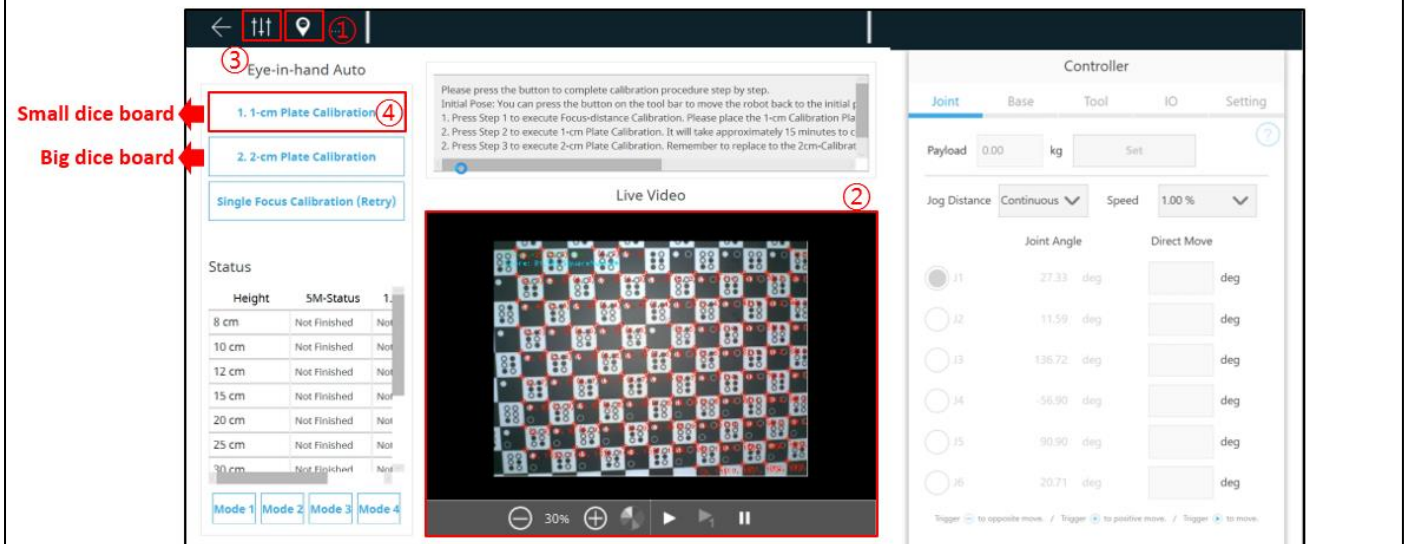

1. Setting up the **big dice board** properly after 1-cm Plate Calibration (small dice board) is completed.
2. Run 2-cm Plate Calibration.

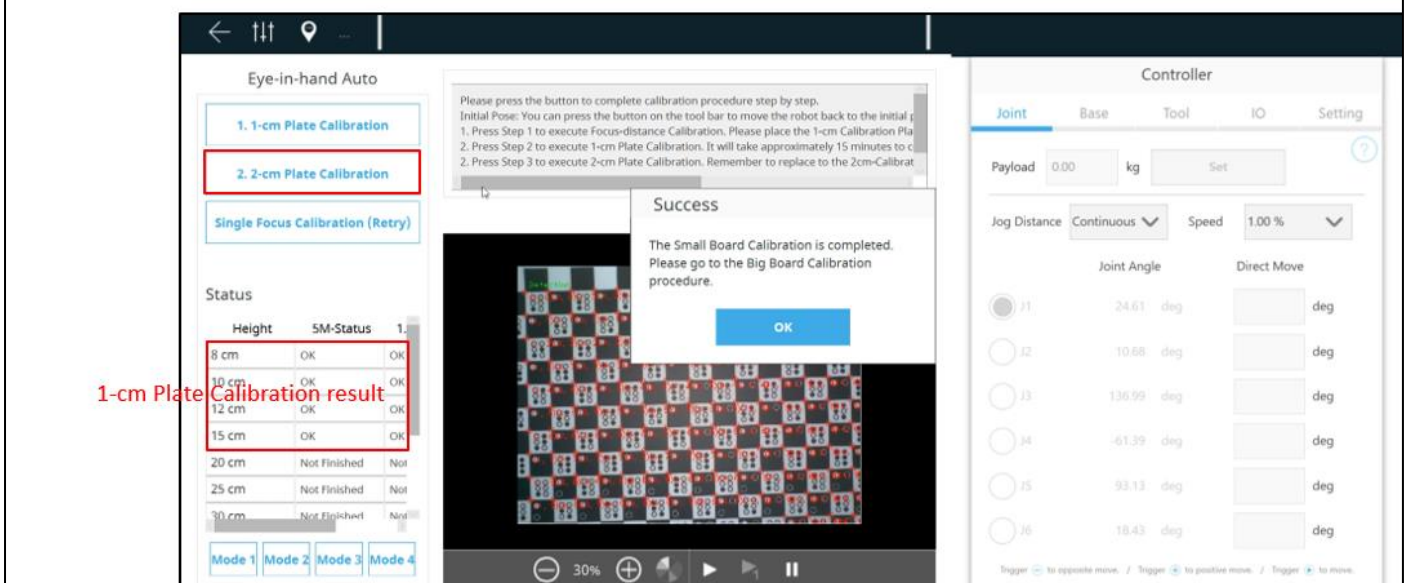

2-cm Plate Calibration completed.

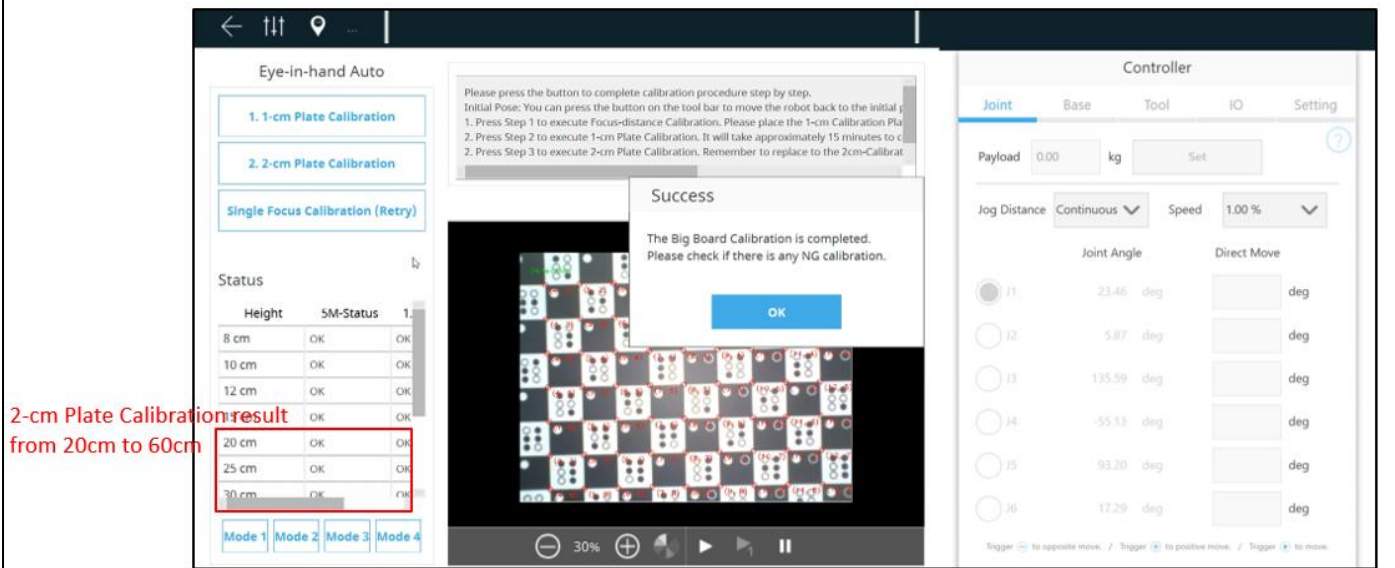

2-cm Plate Calibration result from 20cm to 60cm

1. If there is any status showing 'not finished' after completing the 2-cm Plate Calibration, use 'Single Focus Calibration' for re-calibrating.
2. E.g. 20cm 5M-Status failed. So the 'Board' setting would be 2cm, 'Focus height' would be 20, 'Resolution' would be 5M. Put the big dice board on the camera FOV and click Next.

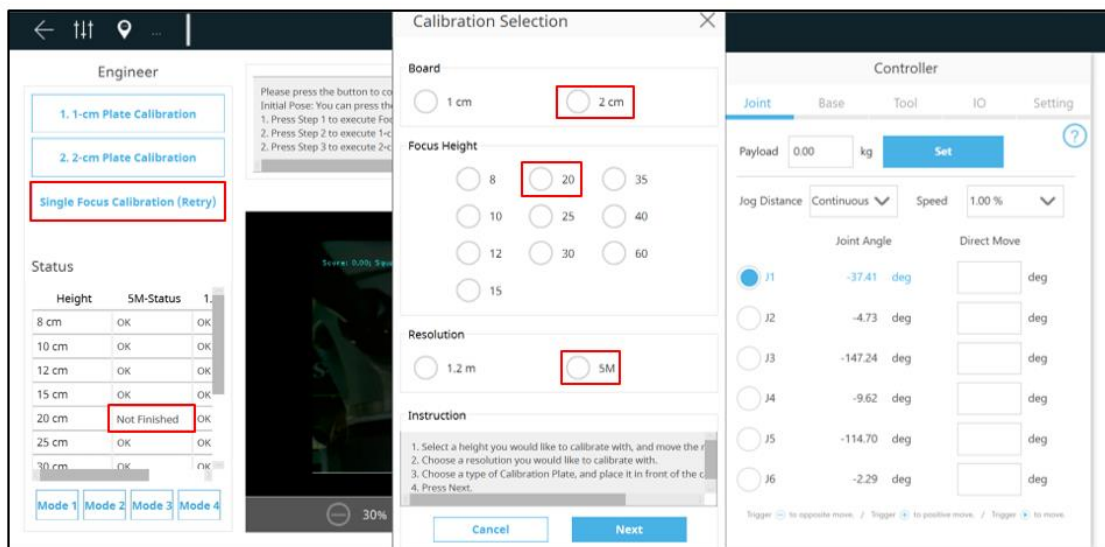

10.6 Kinematic Calibration

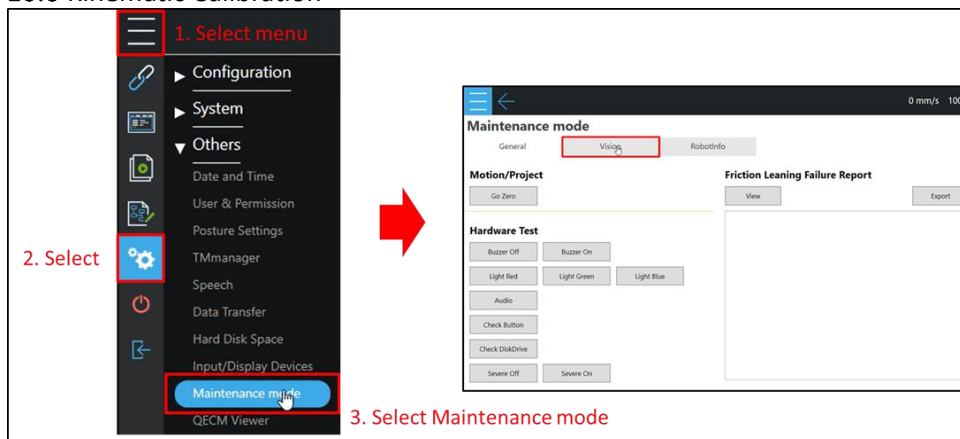

Hardware Version : 5.02 Document Version : 0

TECHMAN ROBOT INC. 5F., No. 58-2, Huaya 2nd Rd., Guishan Dist., Taoyuan City, 333411, Taiwan

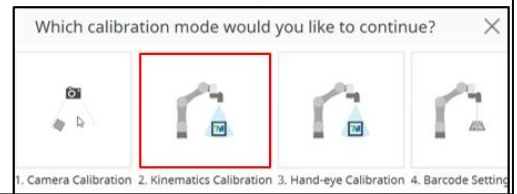
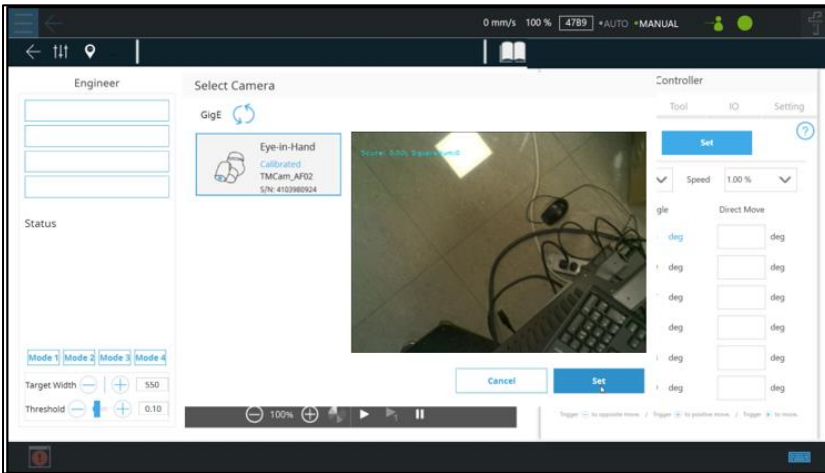

1. Press 'Move to Initial Position' to move the robot to the initial position.
2. Place the **landmark**, turn on the flashlight, and adjust the camera parameters to ensure the landmark is detectable (Green line around the landmark). Ensure that the distance from camera to landmark is between 100mm and 125mm, and the score in the top-left corner of the screen is at least 85 (This value might vary while the robot is moving).
3. Press 'Kinematics Calibration'.

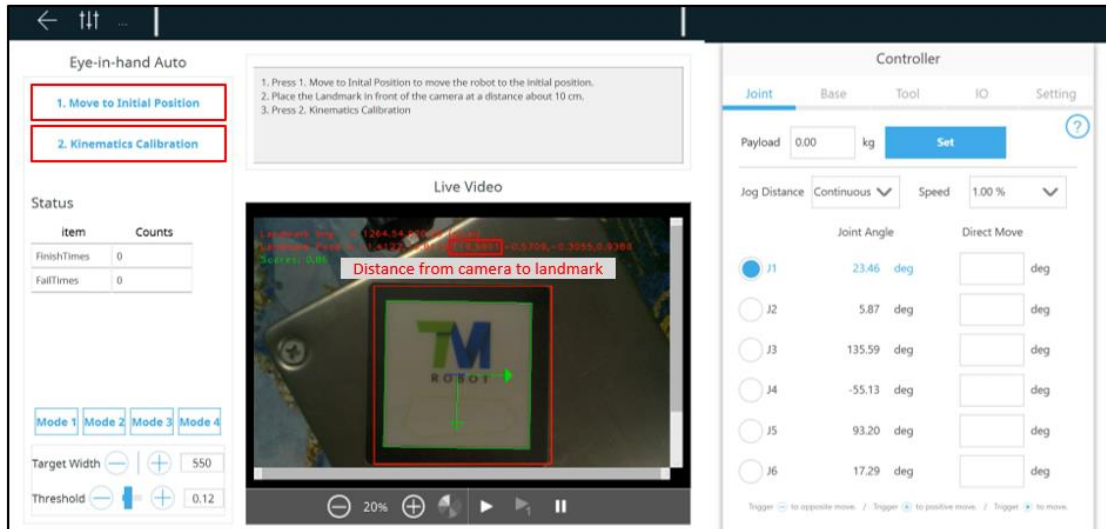

1. Calibration will end upon the successful completion of 40 sets or when failures reach 15 sets.
2. Upon completion, if the error value is lower than 0.3, it means the calibration is successful. If the value exceeds 0.3 or if there are more than 15 times of fail, recalibration is required. At this point, adjust the camera parameters and the surrounding lighting in the field, ensuring that the robot and the platform with the placed landmark remain stable and do not shake.

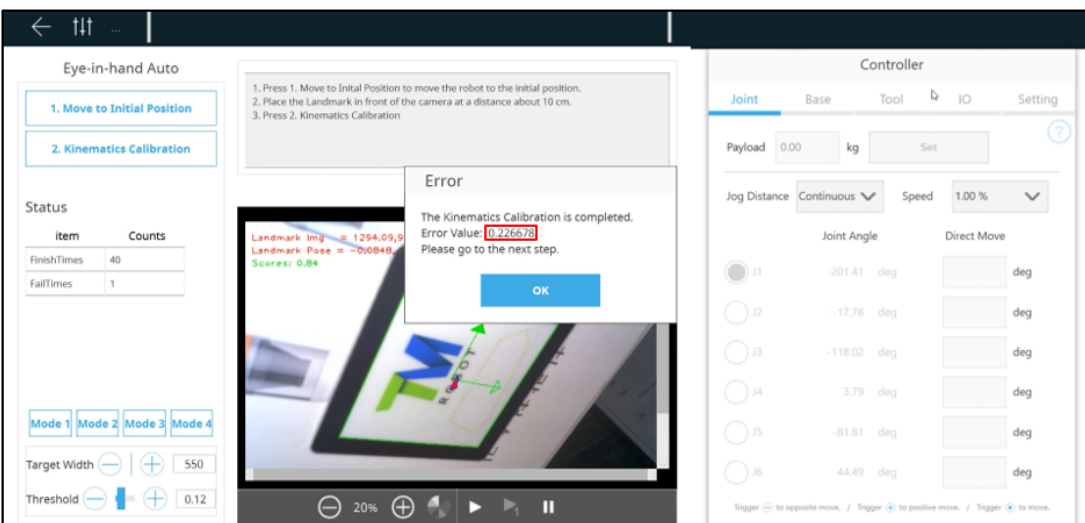

10.7 Hand-eye Calibration & Verification

Hardware Version : 5.02 Document Version : 0

TECHMAN ROBOT INC. 5F., No. 58-2, Huaya 2nd Rd., Guishan Dist., Taoyuan City, 333411, Taiwan

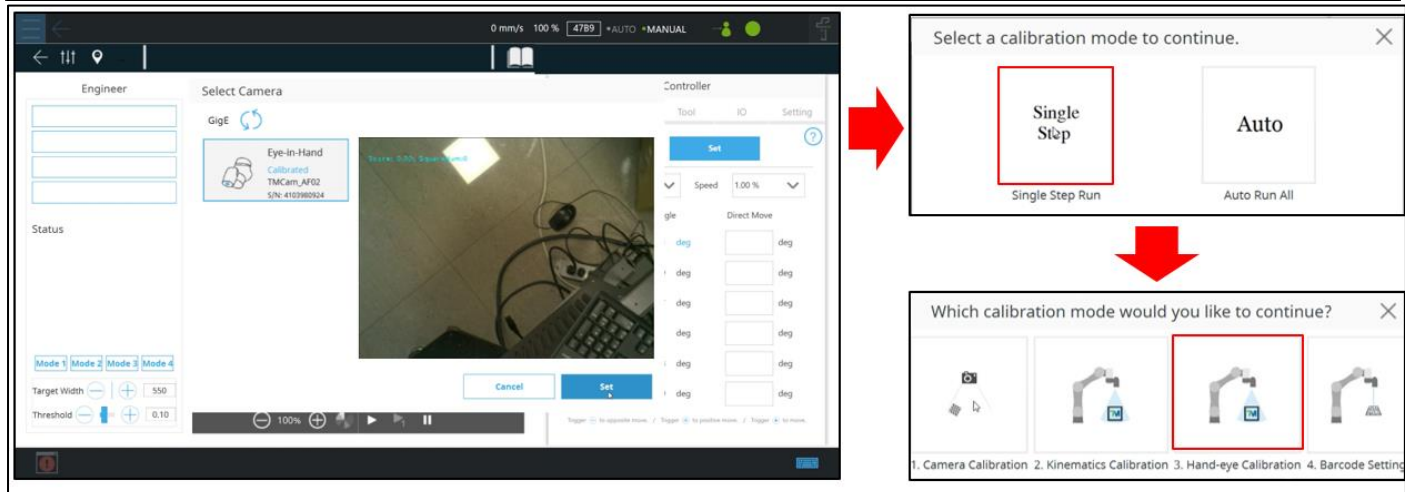
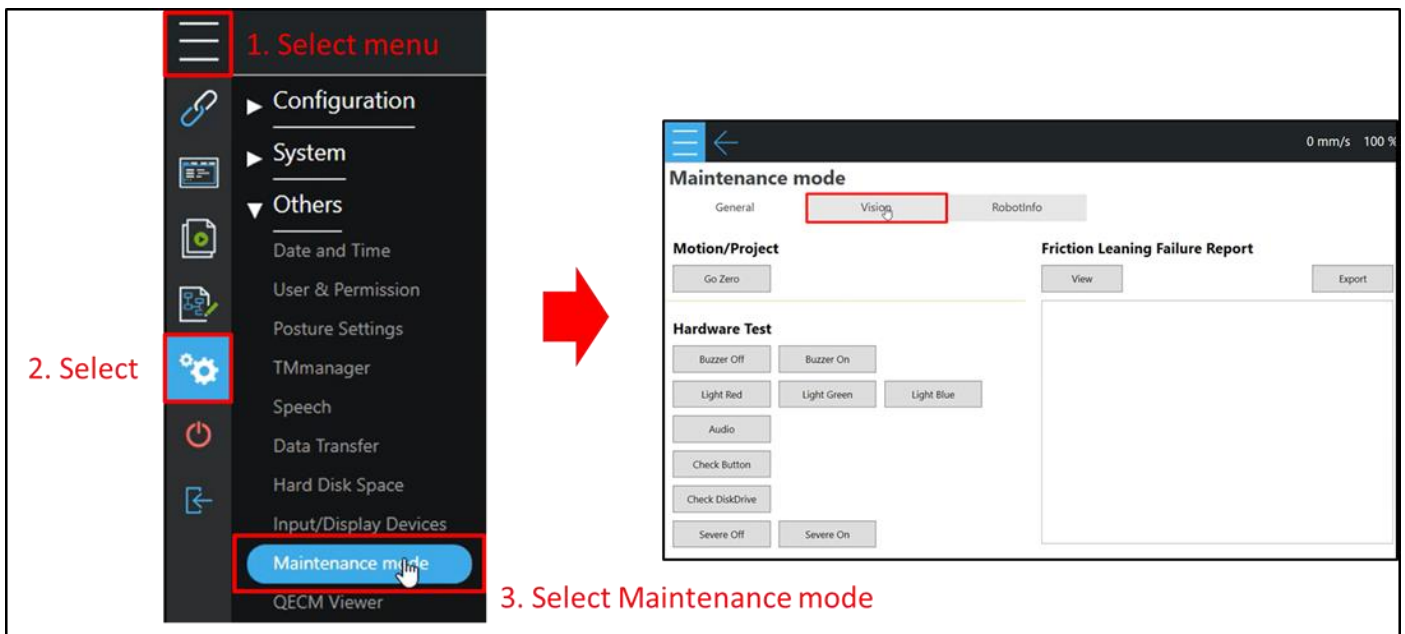

1. Press 'Move to Calibration Position' to move the robot to the designated position.
2. Place the landmark, turn on the flashlight, and adjust the camera parameters to ensure the landmark is detectable (Green line around the landmark). Ensure that the distance from camera to landmark is between 100mm and 125mm, and the score in the top-left corner of the screen is at least 85 (This value might vary while the robot is moving).
3. Press 'Hand-eye Calibration'.

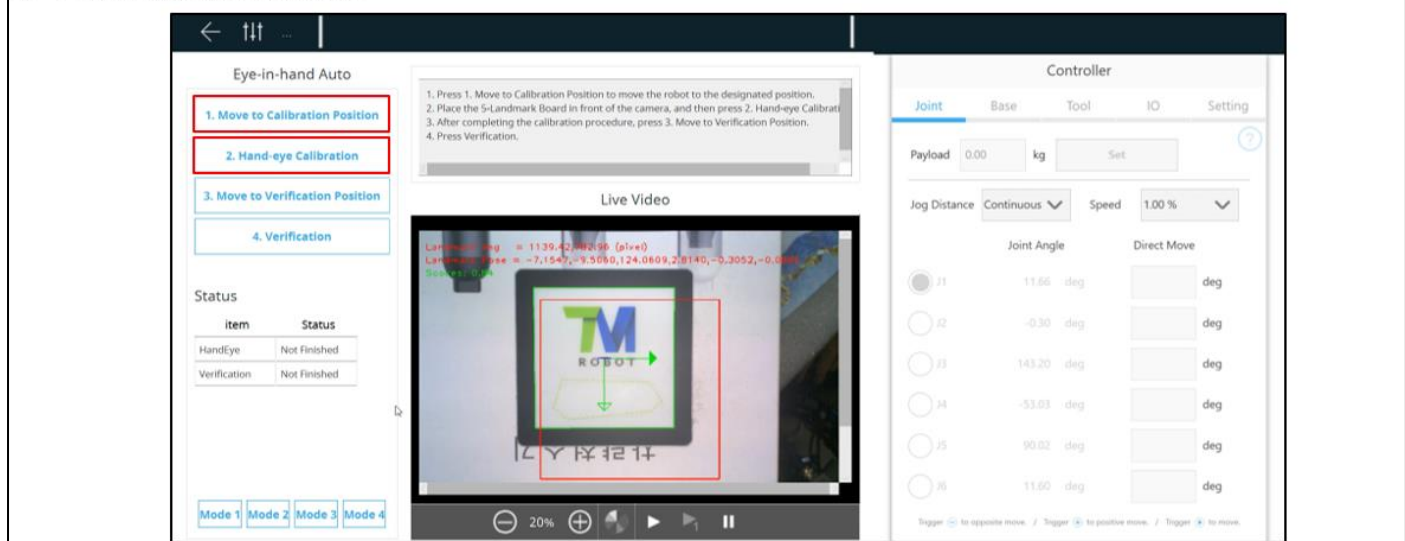

1. Upon completion, if the error value is lower than 0.3, it means the calibration is successful. If the value exceeds 0.3, recalibration is required. At this point, adjust the camera parameters and the surrounding lighting in the field, ensuring that the robot and the platform with the placed landmark remain stable and do not shake.

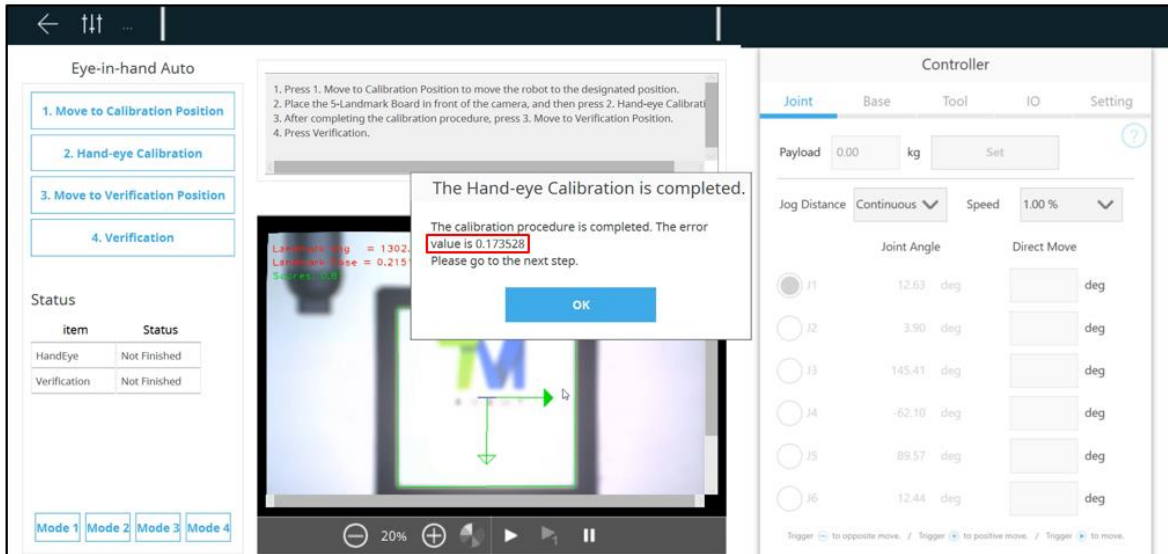

1. Press 'Move to Verification Position' to move the robot to the designated position after completing the hand-eye calibration.
2. Place the **small dice board**, turn on the camera light, and adjust camera parameters to ensure the small dice board can be detected. Then press 'Verification'.

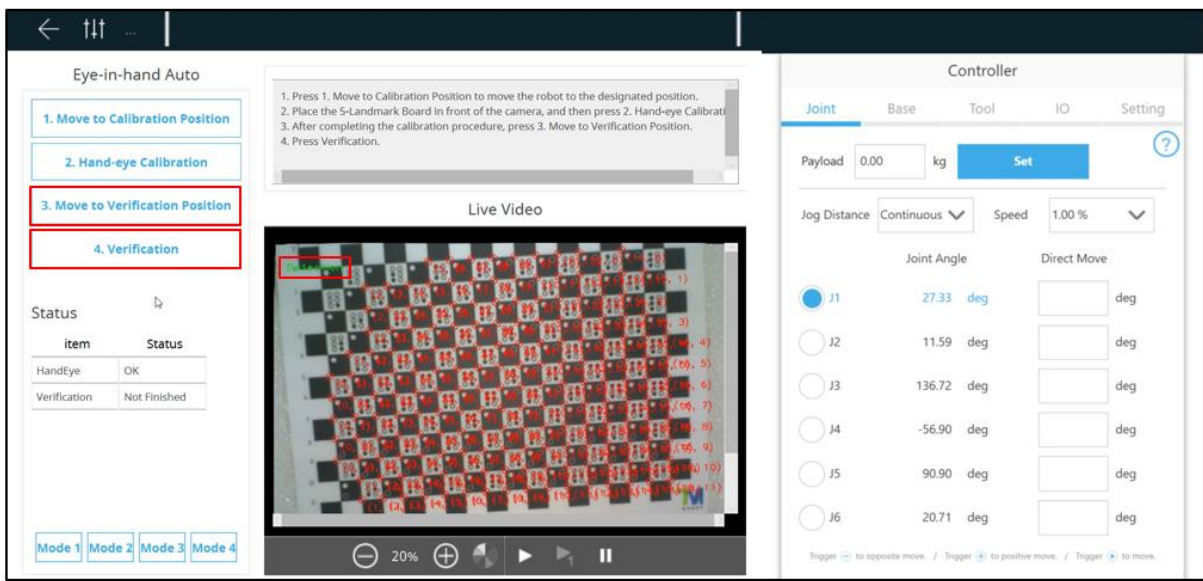

1. After calibration is complete, please ensure that the first and second values are below 0.5, and the third and fourth values are below 1.
2. If any of the values exceed the specified limits, please redo the Hand-eye calibration and Verification.

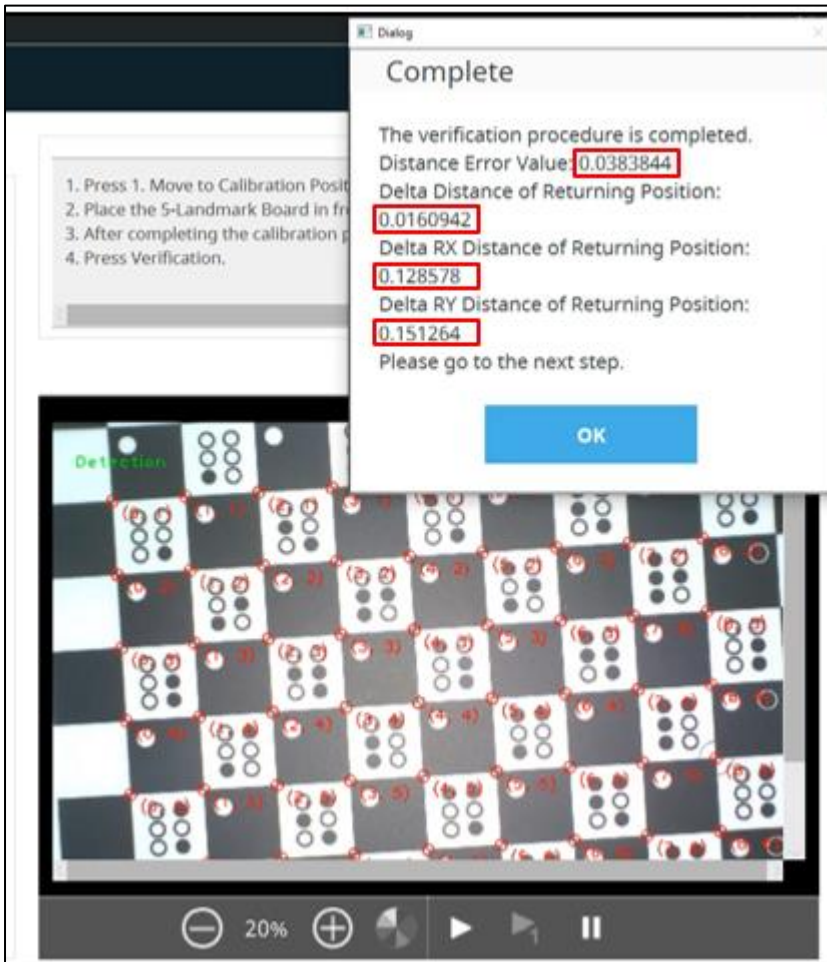
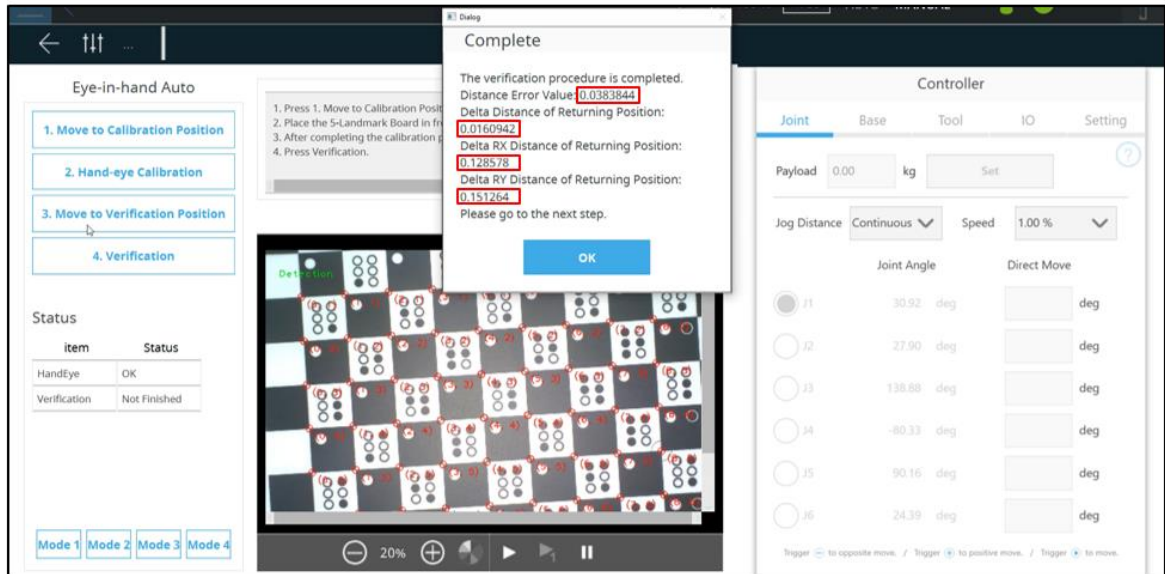

10.8 Barcode setting

1. Select menu

2. Select

3. Select Maintenance mode

Maintenance mode

General **Visio** RobotInfo

Motion/Project: Go Zero

Friction Leaning Failure Report: View Export

Hardware Test: Buzzer Off, Buzzer On, Light Red, Light Green, Light Blue, Audio, Check Button, Check DiskDrive, Severe Off, Severe On

Select a calibration mode to continue.

Single Step Auto

Single Step Run Auto Run All

Which calibration mode would you like to continue?

1. Camera Calibration 2. Kinematics Calibration 3. Hand-eye Calibration 4. Barcode Setting

1. Press 'Move to Barcode Position' to move the robot to the initial position.
2. Press 'Camera Parameter Auto Once' to set the camera parameter automatically.

Eye-in-hand Auto

1. Move to Barcode Position

2. Camera Parameters Auto Once

3. Set Barcode as Target

4. Save Setting

Status

item	Shift Pixel
Barcode	0.666667

Live Video

Controller

Joint Base Tool IO Setting

Payload 0.00 kg Set

Jog Distance Continuous Speed 1.00 %

Joint	Joint Angle	Direct Move
J1	-37.41 deg	deg
J2	-4.73 deg	deg
J3	-147.24 deg	deg
J4	-9.62 deg	deg
J5	-114.70 deg	deg
J6	-2.29 deg	deg

Hardware Version : 5.02 Document Version : 0

TECHMAN ROBOT INC. 5F., No. 58-2, Huaya 2nd Rd., Guishan Dist., Taoyuan City, 333411, Taiwan

1. Press 'Set Barcode as Target' to save the present barcode location.
2. Press 'Save setting' and finish the calibration.

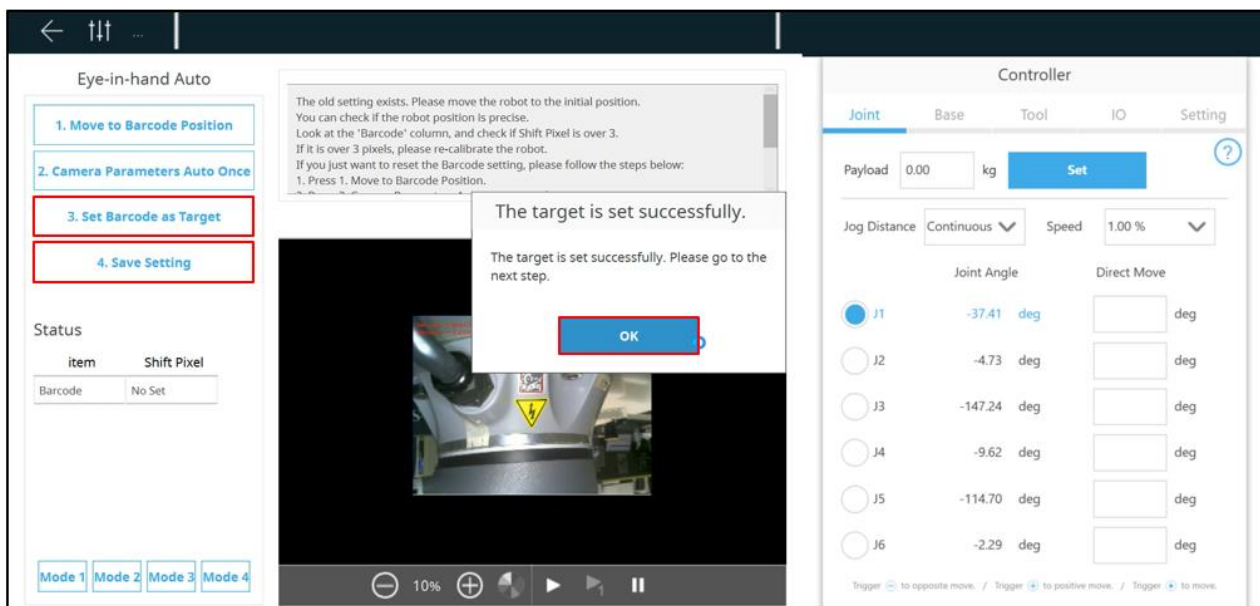

10.9 Save the calibration data

1. Go to 'Maintenance mode', select 'Safety'
2. Enter 00000000 and select Login, and then press 'OK'

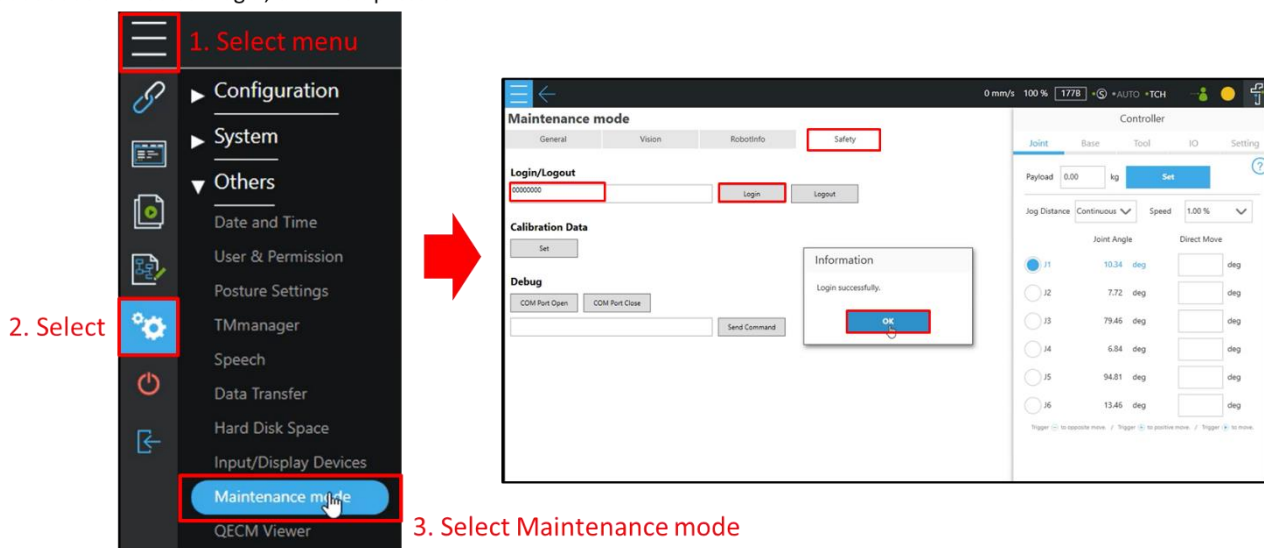

1. Press 'Set' to upload the calibration data from control box to arm
2. Press 'OK' and the TMflow will shut down automatically

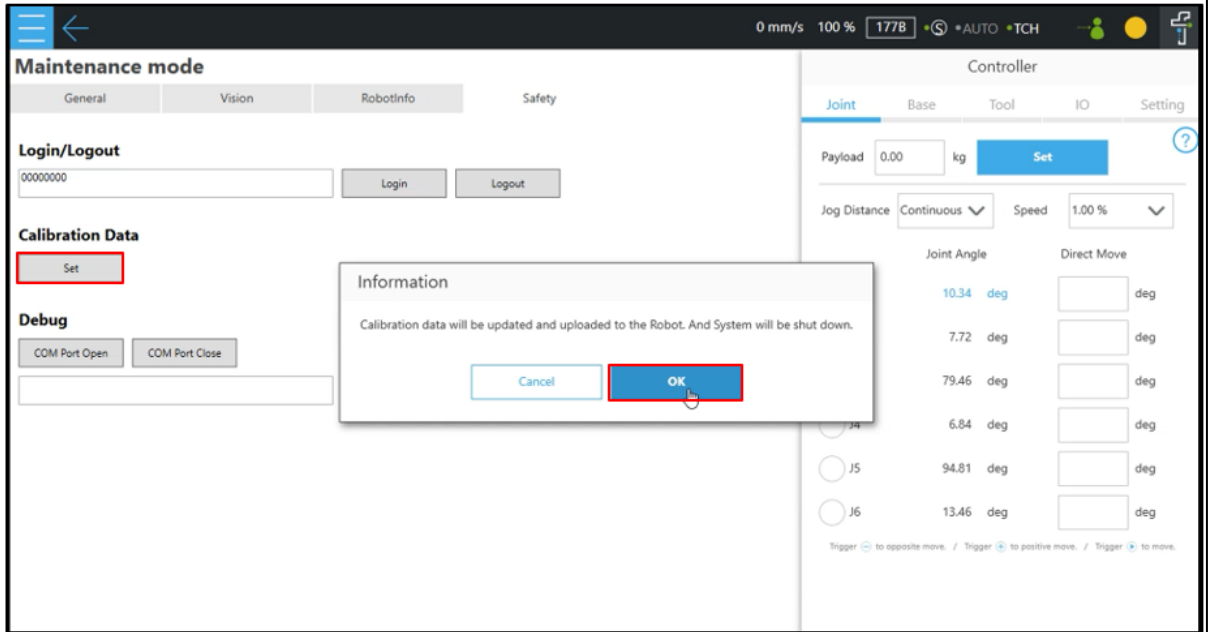

11. Trouble shooting

11.1 Camera disconnection

Symptom description

EIH camera disconnected while using / EIH camera can not be detected

Possible causes

This issue may be caused by following reasons/components:

1. IPC
2. Internal complex cables
3. Robot cable
4. Camera cables inside the robot arm
5. TRI camera
6. System or driver

Symptom photos Or Error codes

0x00020000
0x00020003

Notices

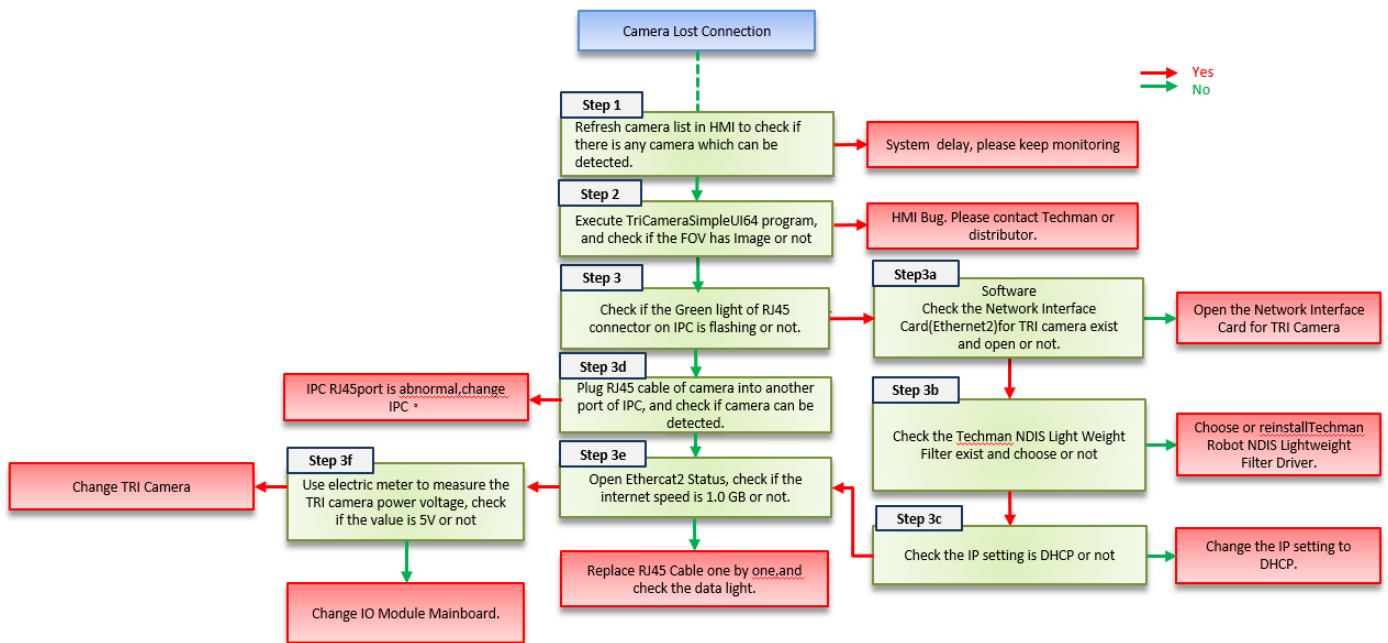

TriCameraSimpleUI64

The TriCameraSimpleUI64 executable file is on the Control Box above HMI Vesion2.0.

Execute the following path file

D:\TRI_Camera\TriCameraSimpleUI64.exe

Step

1. Showing the camera
2. Connect (click)
3. Continuous(click)
4. Check if there is image on FOV

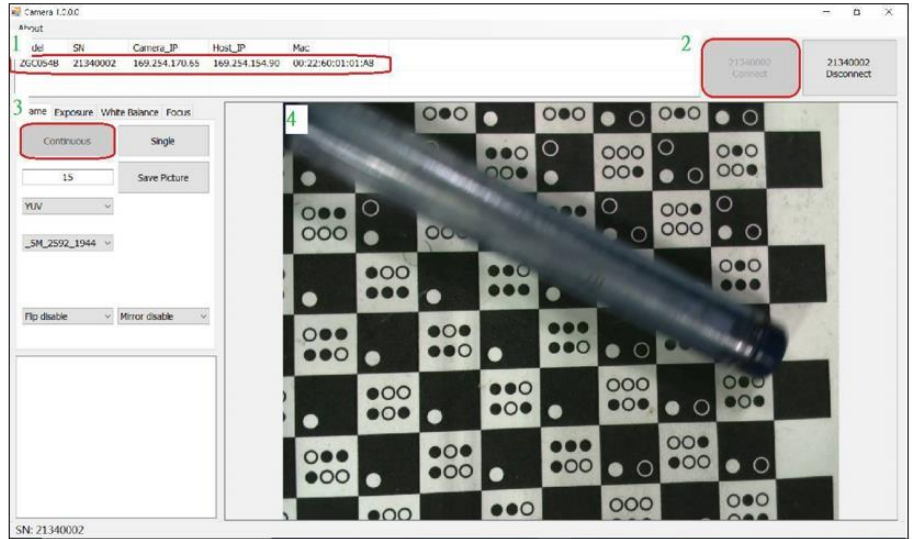

Check camera port on IPC

Check if the RJ45 Cable port on IPC flashes or not

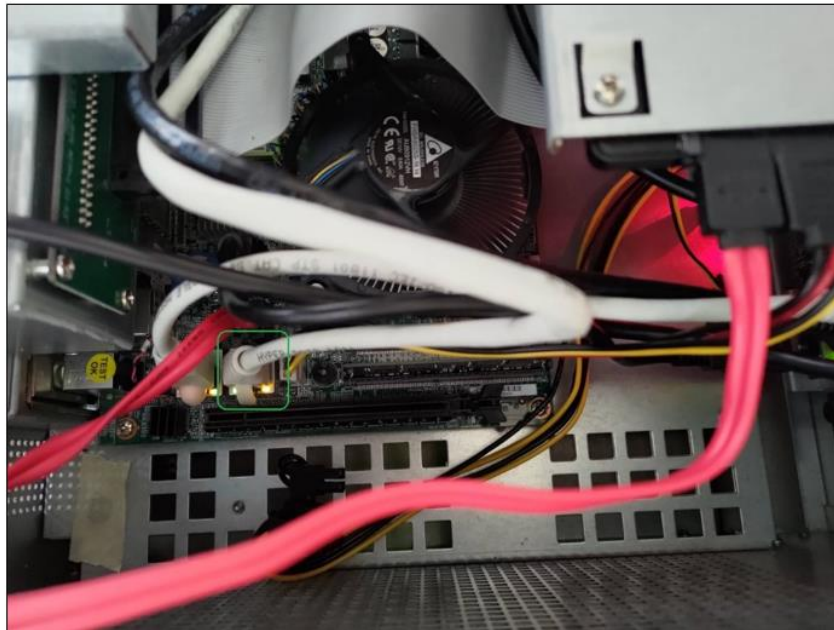

Check Network setting_1

1. Go to Control Pane -> Network and Internet -> Network and Sharing Center -> Change adapter settings
2. Check whether the Network Interface Card(Ethernet2)for TRI camera exists or not, and it should be activated.

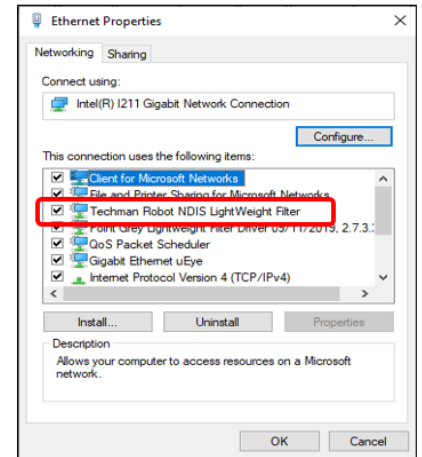
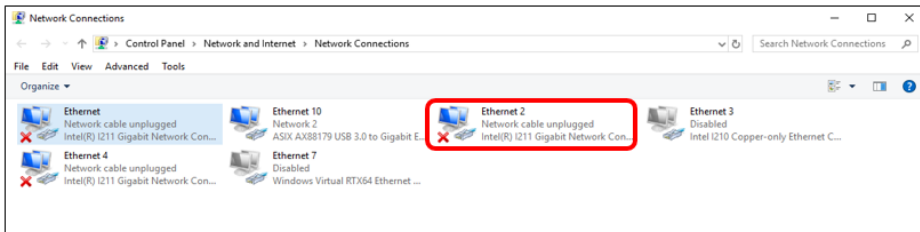

3. Right click the Ethernet2 and choose properties, check whether the Techman NDIS Light Weight Filter exists or not.

Check Network setting_2

1. Choose Internet Protocol version4 and then choose properties. Check whether the IP setting is DHCP, set it as DHCP.

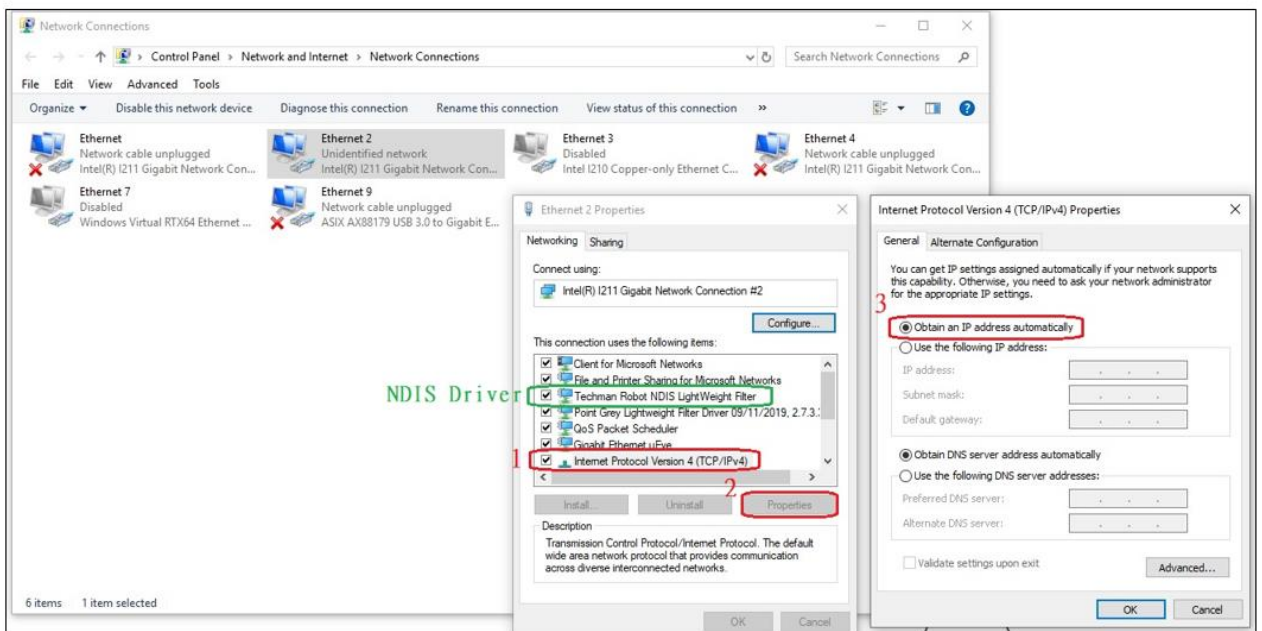

Check Network setting_3

1. Choose Ethernet2, and check whether the Ethernet Speed is 1.0 Gbps or not; if not, it means the problem could be caused by hard ware components.

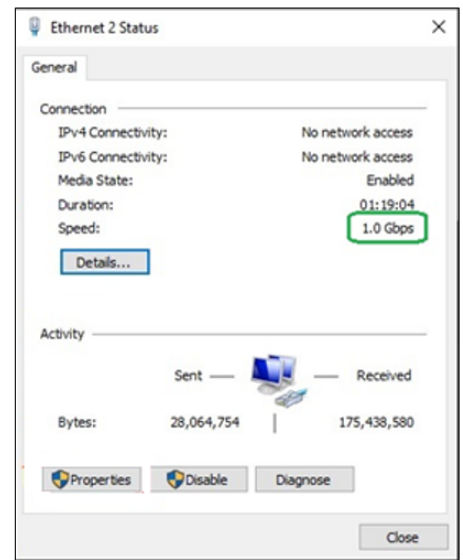
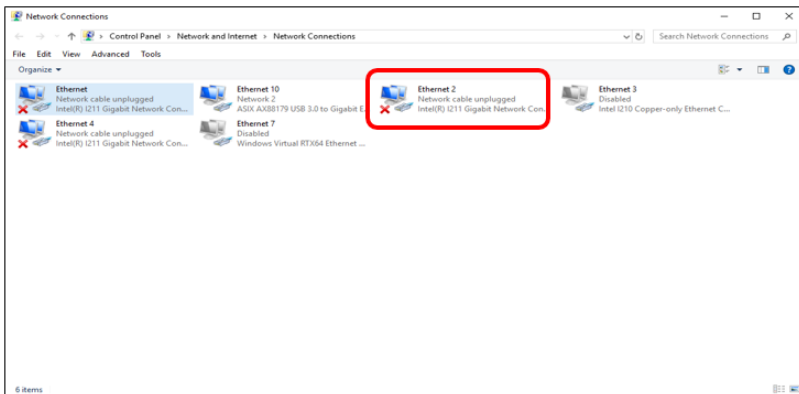

Check TRI camera

1. Follow Picture 1 to remove the Camera housing.
2. Use multi-meter to measure the TRI camera power voltage, check if the value is 5V or not as picture 2 & 3



Picture 1 - Remove camera housing screw



Picture 2 - Measure TRI camera Power

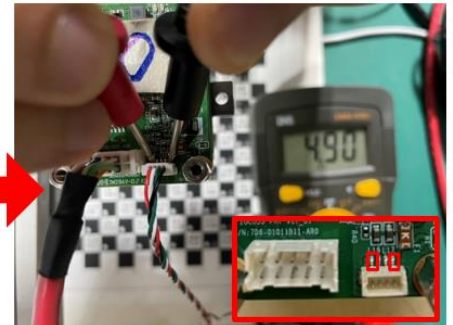

Picture 3 - Measure pins

Check TRI Camera_LED indicators

1. The orange light on the left indicates link status, signifying that the RJ45 signals on both sides(IPC and TRI camera) are connected.
2. The yellow light on the right represents data, and it illuminates when data is being transmitted.
3. When capturing a picture, the blinking frequency will be faster. In principle, please use the data light to verify whether the TRI camera Ethernet is active or not.



11.2 Camera won't focus

Symptom description

EIH camera can not focus by HMI adjustment

Possible causes

This issue may be caused by following reasons/components:
1. HMI
2. Camera

Symptom photos Or Error codes

N/A

Notices

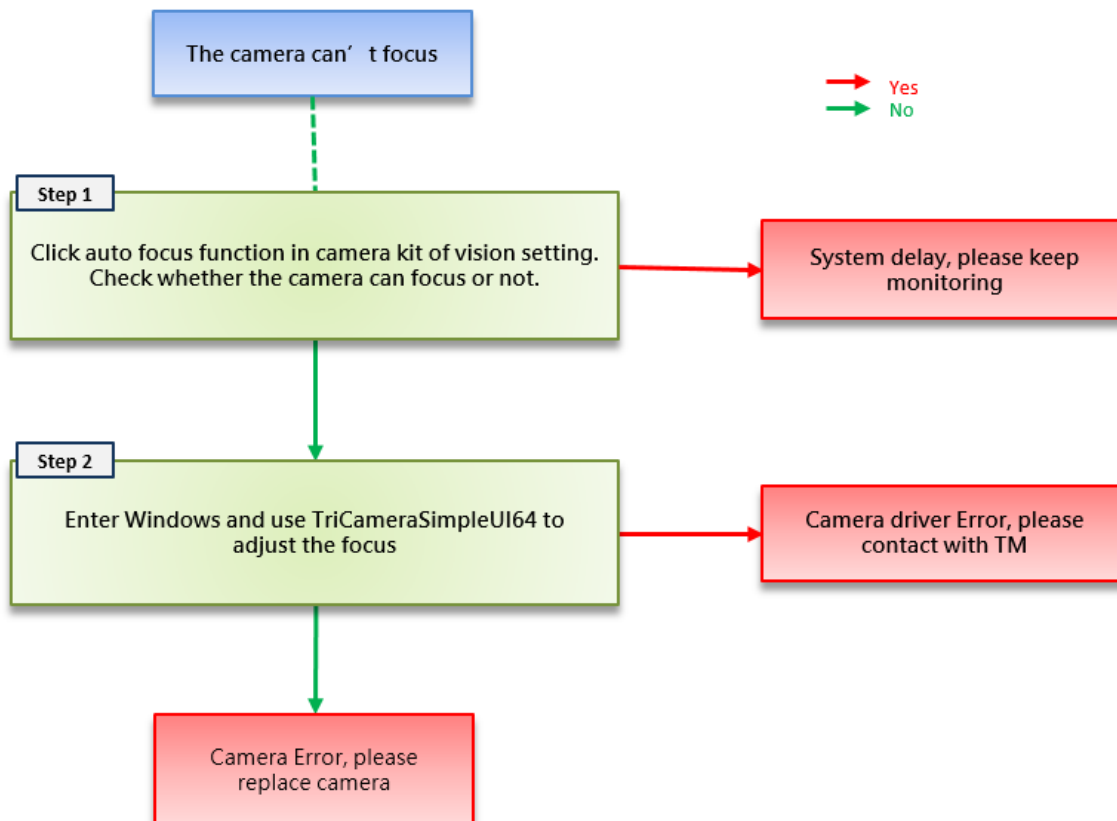

11.3 Point offset

Symptom description The robot cannot reach the previous position after a collision or for an unknown reason. This issue typically arises following a collision or relocation.

Possible causes This issue may be caused by following reasons/components:
 1. Joint
 2. End module
 3. Surrounding equipment

Symptom photos Or Error codes N/A

Notices

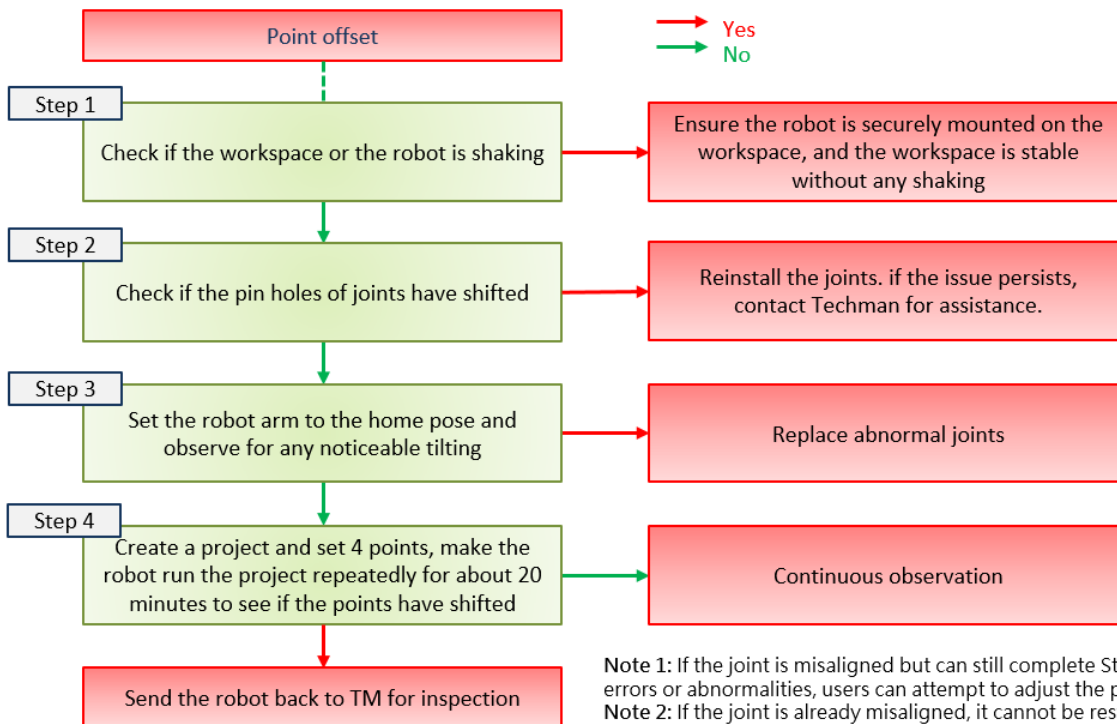

11.4 Control box fails to boot up

Symptom description

Control box fails to boot up after pressing the power key on the stick

Possible causes

This issue may be caused by following reasons/components:

1. Stick
2. Relay board
3. 24V PSU
4. Patriot power board

Symptom photos Or Error codes

N/A

Notices

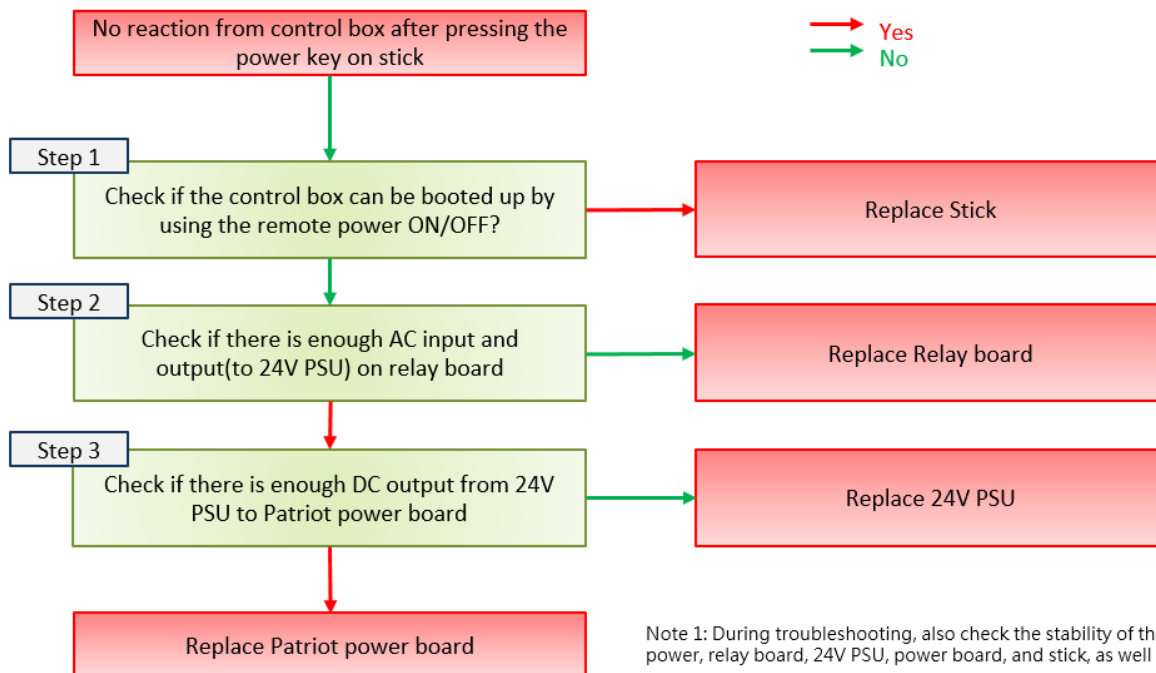

11.5 Encoder Error

Symptom description TMflow shows messages relating to encoder error or encoder compensation error

Possible causes This issue may be caused by following reasons/components:
1. Joint

**Symptom photos
Or Error codes** 0xFFCE / 0xFFED / 0xFFE4

Notices When encountering Encoder-related anomalies, determine which joint is causing the issue based on the Error code displayed in TMFlow, and request replacement for the affected joint.

11.6 Robot arm does not activate

Symptom description There is no power supply from the control box to the robot arm, and the indicator light ring on the end module does not illuminate even after the control box has been booted up.

This issue may be caused by following reasons/components:

- Possible causes**
1. Power relay board
 2. 48V PSU(Power supply)
 3. Patriot power board
 4. Power eater
 5. Joints
 6. End module

**Symptom photos
Or Error codes** 0x3E / 0x53 ...

Notices When addressing this 48V circuit issue, we recommend starting by disconnecting the robot and control box. This step will help you identify and narrow down the range of components that need to be checked.

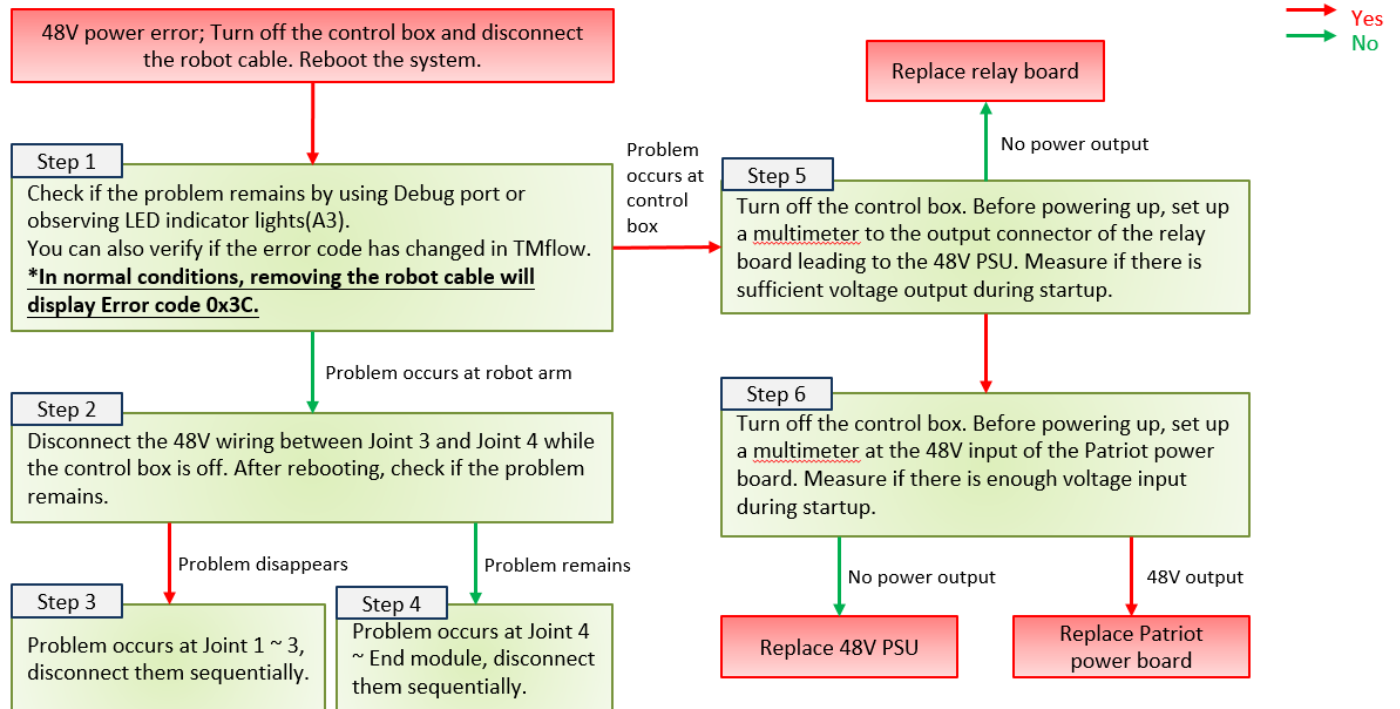

11.7 TM Safe error

Symptom description Can not access TMflow normally, showing error codes below.

Possible causes The error may be caused by following reasons/components:

1. Joint
2. Patriot power board

Symptom photos Or Error codes 0xCE, 0xCF, 0x4E017, 0xDD28, 0x45F071, 0x55F071, 0x65F071, Open RTSS Fail

Notices When addressing this trouble shooting, we recommend starting by disconnecting the robot and control box, and check if the error code changes. This step will help you identify and narrow down the range of components that need to be checked.

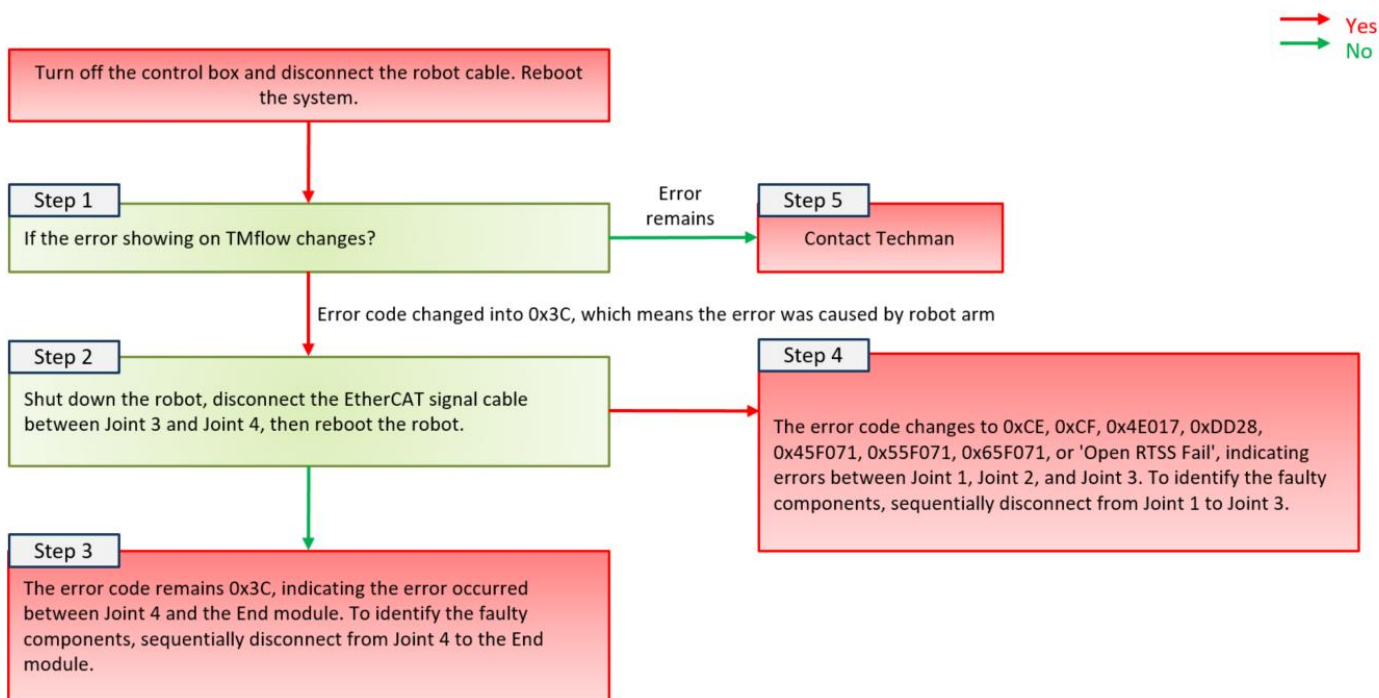

11.8 Torque error

Symptom description

During robot operation, it displays that torque limits exceed the standard.

Possible causes

The error may be caused by following reasons/components:

1. TCP settings do not match reality
2. Obstacle or interference detected along the arm's motion path
3. Abnormality in joint
4. Safety parameter abnormality

Symptom photos Or Error codes

0x22, 0xFF08, 0xFF0B, 0xFF0E, 0xFF11, 0xFF14, 0xFF17, 0xFFCF

Notices

When addressing this trouble shooting, it is recommended to first check whether there is any interference with other objects along the arm's motion path. Prolonged interference or collisions may lead to a shortened lifespan of the Harmonic Drive within the joint."

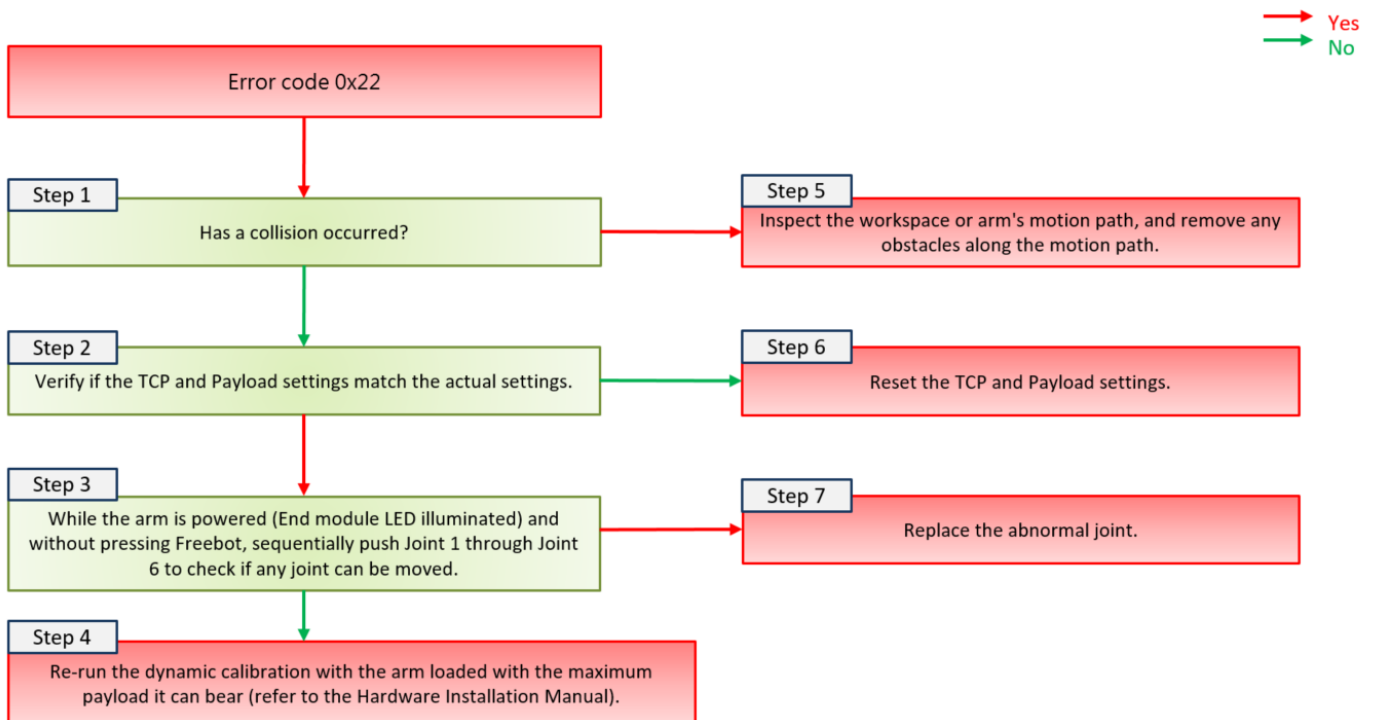

11.9 Kinematic calibration failed

Symptom description Kinematic calibration failed

Possible causes

The error may be caused by following reasons/components:

1. Camera malfunction
2. Environmental abnormalities
3. Landmark
4. Joint malfunction
5. HMI Bug

**Symptom photos
Or Error codes** NA

Notices

